



  
scolaro®

## SAIL PARASOL

04. Vela

## RETRATTILI/RETRACTABLES

06. Galileo Inox

08. Galileo White

10. Galileo Dark

12. Galileo Maxi 4x4

## BRACCIO/SIDE POST

14. Giotto Braccio

16. Milano Braccio

18. Leonardo Braccio

20. Palladio Braccio

22. Napoli Braccio

24. Rimini Braccio

26. Torino Braccio

## STANDARD

28. Milano Standard

30. Napoli Standard

32. Palladio Standard

## TELESCOPIC

34. Leonardo Telescopico

36. Palladio Telescopico

38. Capri

## GRANDI COPERTURE/SPECIAL STRUCTURES

40. Milano Poker/Double

42. Alu Poker/Double

44. Wood Poker/Double

46. BASI/BASES

50. SCHEDE TECNICHE/TECHNICAL SCHEDULES

68. MATERIALI E FINITURE/MATERIALS AND FINISHING

70. NEW SYSTEM

71. SOLE LIGHT

72. REFERENZE/REFERENCES



VERONA, Piazza delle Erbe - 1976



- I Scolaro è un'azienda nata più di 40 anni fa come antico laboratorio artigianale di ombrelloni DOC. L'ampia gamma di articoli è studiata per il Contract, l'arredo giardino e il settore pubblicitario ed è costituita da ombrelloni in legno e alluminio con palo centrale, palo laterale e con telaio telescopico. La politica aziendale costantemente rivolta alla soddisfazione del cliente finale consente ora alla Scolaro di esportare i propri prodotti in più di 50 Paesi. Alla esperienza e capacità manipolativa aggiunge negli anni sempre maggiori tecnologie per migliorare lo standard qualitativo e da semplice prodotto per riparare dal sole ne ha fatto un elegante strumento per l'arredamento personalizzato. Il design, le nuove soluzioni tecniche e l'abbinamento dei materiali migliori, segnano l'evoluzione e l'utilizzo dell'ombrellone, il tutto garantito da un processo produttivo interamente italiano.
- UK The company Scolaro was established 40 years ago and produced artisan wooden parasols. Our wide range of articles is studied for the Contract, the garden furniture and the promotional branch. It includes wooden and aluminium parasols with central pole, side post and telescopic frame. Our company's policy is constantly seeking to customer satisfaction and allows now to export our products in more than 50 countries. The experience and manipulative skill added over the years more and more technologies to improve the quality standard and a simple product developed to shelter from the sun has become an elegant tool to personalize smartly furnishing. The design, new technical solutions and the combination of the best materials, mark the evolution and use of the parasol, guaranteed by an entirely Italian production process.
- D Die Firma Scolaro wurde vor ueber 40 Jahren gegrueudet und stellte urspruenglich handwerksmaessig Qualitaetssonenschirme her. Unsere umfangreiche Auswahl an Artikel eignet sich fuer Gastro-OH, Gartenmoebel Fachhandel und den Werbebereich und schliesst Mittelmast-, Pendel- sowie Teleskopschirme in sich. Die Kundenzufriedenheit ist einer unserer prinzipiellen Objektiv und hat uns erlaubt nun in ueber 50 Laender zu exportieren. Unsere Erfahrung und Handfertigkeit haben alle Erwartungen nach einer besseren Technologie und nach einem hohen Qualitaetsstandard erfuellt. Ein einfaches Produkt zum Schutz vor der Sonne, verleiht heute der Einrichtung eine persoehnliche und elegante Note. Das Design, die technischen Verbesserungen, die Kombination hochwertigster Materialien und das italienische Produktionsprozess kennzeichnen die Entwicklung und den Einsatz des Schirmes.
- F La maison Scolaro a commencé son activité il y a 40 ans avec la production artisanale de parasols en bois. Notre large gamme de parasols est adaptée à l'hôtellerie, le jardin et le marché publicitaire. Elle comprend des parasols avec mâts centraux, mâts déportés et télescopiques. La politique de l'entreprise est constamment à la recherche de la satisfaction des clients. La Société SCOLARO exporte ses parasols dans plus de 50 pays. L'expérience et les compétences de fabrication acquises au fil des ans et les nouvelles technologies ont permis d'améliorer la qualité et un produit simple de la protection du soleil est devenu un objet élégant de mobilier de jardin. Le design, les solutions techniques et la combinaison des meilleurs matériaux soulignent l'évolution et l'utilisation du parasol, garantie par un processus de production entièrement italien.
- E La empresa SCOLARO, fue fundada hace más de 40 años como laboratorio artesano de parasoles. La amplia gama de productos está estudiada para contract, jardín y el sector publicitario, fabricando parasoles tanto en madera, como en aluminio con mastil central o lateral y con estructura telescópica. La política de la empresa está constantemente dirigida a la satisfacción del cliente final, lo que con el tiempo ha permitido que scolaro exporte su producto a más de 50 países. A la experiencia y capacidad manipuladora, hemos incorporado con los años mayores tecnologías para mejorar la normativa de calidad y hacer de un simple producto para protegerse del sol un instrumento elegante para el interiorismo personalizado. El diseño, las nuevas soluciones técnicas y la combinación de los mejores materiales, marca la evolución y utilización de los parasoles, garantizando que todo el producto es de fabricación íntegramente italiana.
- NL Parasolfabrikant SCOLARO startte meer dan 40 jaar geleden met de handmatige fabricage van parasols van hoge kwaliteit. In het uitgebreide assortiment zijn parasols voor zowel gastronomie, tuinmeubelvakhandel als ook voor reclamedoeleinden opgenomen. Parasols zijn, zowel in hout als aluminium, leverbaar als zwevend, met centrale mast en in telescoop uitvoering. Klanttevredenheid is onze bedrijfspolicy. Wij exporteren onze parasols naar meer dan 50 landen. Door onze jarenlange ervaring, opgebouwde kennis en verbeterde technologie zijn wij in staat een hoogwaardig product te fabriceren. Een eenvoudig artikel ter bescherming tegen de zon vraagt tegenwoordig een persoonlijke en elegante uitstraling. Design, nieuwe technische oplossingen in combinatie met hoogwaardige materialen zijn kenmerkend voor de ontwikkeling en het gebruik van Scolaro parasols, waarvan de productie volledig in Italiaanse handen is.

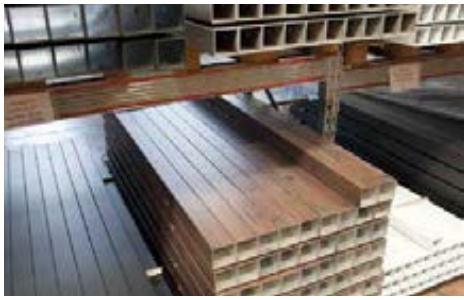



- I I nostri articoli sono progettati, sviluppati e prodotti interamente all'interno della nostra azienda con sede in Italia. Particolare cura per la rifinitura e il controllo di qualità sono parte integrante della nostra politica. Grazie ai materiali impiegati e ai dispositivi tecnici i nostri articoli sono particolarmente robusti e adatti per un uso intenso e professionale. L'utilizzo di tessuti acrilici impermeabili, di legno, acciaio e alluminio trattati ne garantiscono una lunga vita. La ditta Scolaro presta particolare attenzione alla facilità di manutenzione e alla disponibilità di componenti di ricambio garantita nel tempo. Al raggiungimento di tali risultati ha sempre collaborato l'Ombrellificio D'Inca che tuttora si occupa della confezione delle coperture.
- UK Our products are designed, developed and manufactured entirely inside our company based in Italy. Special care for finishing and quality control are an integral part of our policy. Thanks to the materials used and the technical equipment, our items are strong and suitable for heavy and professional employ. The use of waterproof acrylic fabrics, treated wood, steel and aluminium grant a long life. Particular attention for an easy maintenance and the availability of spare parts is guaranteed over time. To the achievement of these results has always cooperated the company Ombrellificio D'Inca, that still takes care of the parasol cover manufacture.
- D Unsere Produkte werden in unserem Unternehmen mit Sitz in Italien geplant, entwickelt und produziert. Besondere Sorgfalt fuer Feinbearbeitung und Qualitätskontrolle sind Bestandteil unserer Politik. Dank der verwendeten Materialien und der technischen Ausstattung sind unsere Produkte sehr stark und fuer einen gewerblichen Einsatz geeignet. Die Verwendung wasserfester Acrylstoffe, behandelte Materialien wie Holz, Stahl und Aluminium gewährleisten eine lange Lebensdauer. Grossen Wert legen wir auf eine Vereinfachung der Wartung und Erhältlichkeit von Ersatzteilen selbst nach vielen Jahren. Diese Ergebnisse konnten auch dank der Zusammenarbeit mit der Firma Ombrellificio D'Inca, die fuer die Produktion der Schirmbezüge zuständig ist, erzielt werden.
- F Nos produits sont conçus, développés et fabriqués entièrement au sein de notre société basée en Italie. Une attention particulière pour la finition et le contrôle de la qualité font partie intégrante de notre politique. Grâce aux matériaux utilisés et l'équipement technique, nos produits sont résistants et adaptés à un usage intensif et professionnel. L'utilisation de tissus en acrylique imperméables, ainsi que les matériaux bois, acier et aluminium traité, garantissent une longue durée de vie à nos parasols. L'entreprise SCOLARO accorde une attention toute particulière à la facilité d'entretien des parasols et à la disponibilité de pièces de rechange garanties dans le temps. La société Ombrellificio D'Inca a toujours collaboré à la réalisation des toiles qui contribuent au succès de la qualité de nos parasols.
- E Nuestros artículos están diseñados, desarrollados y producidos íntegramente en nuestra fábrica de Italia. Nuestra particular atención al acabado y a los controles de calidad forman parte de nuestra política de empresa. Gracias a los materiales empleados y a los dispositivos técnicos, nuestros productos son particularmente robustos y se adaptan a un uso intenso y profesional. La utilización de tejidos acrílicos impermeabilizados, maderas tratadas, acero y aluminio garantizan una larga durabilidad del producto. La firma Scolaro presta particularmente atención al fácil mantenimiento y a la disponibilidad de repuestos durante mucho tiempo. El logro de estos resultados también se debe a la colaboración de la empresa Parasoles D'Inca, la cual se ocupa de la confección de la cobertura textil.
- NL Onze producten worden in onze eigen fabriek in Italië geproduceerd. Extra zorg aan de afwerking en de kwaliteitscontrole zijn een vast onderdeel van ons fabricageproces. Dankzij de gebruikte materialen en de technische uitrusting zijn onze producten zeer sterk en geschikt voor professioneel gebruik. Het gebruik van waterbestendig acryl en behandelde materialen als hout, metaal en aluminium staan borg voor een lange levensduur. Bijzondere zorg besteden wij aan een vereenvoudiging van onderhoud en beschikbaarheid van vervangende onderdelen, ook na vele jaren. Deze resultaten worden mede gerealiseerd door de jarenlange samenwerking met de firma Ombrellificio D'Inca, doekenleverancier voor onze parasols.





*Sail-parasol*

## Vela



I L'ombrellone Vela ridefinisce il concetto e l'architettura dell'ombra, inedito e fuori dagli schemi. Il design della copertura si evolve lasciandosi ispirare dal mare e sagomare dal vento, ottenendo linee sinuose ed ergonomiche. Dalla fusione armonica tra un ombrellone e una vela nasce una sinergia tra resistenza dei materiali e leggerezza delle forme. Un oggetto unico per valorizzare il Vostro ambiente esterno.

UK The parasol Vela redefines the concept and architecture of the shadow, unusual and unconventional. The cover design evolves taking inspiration from the sea and shaped by the wind, resulting in sinuous and ergonomic lines. From the harmonic fusion between a parasol and a sailing a synergy between material strength and lightness of form, takes shape. A unique item to enhance your outdoor environment.

D Der Sonnenschirm Vela definiert den Begriff und die Architektur des Schattens, ungewöhnlich und unkonventionell. Das Design der Bespannung lässt sich vom Meer inspirieren und durch den Wind modeln. Ergebnis sind ergonomische und gewundene Linien. Von der harmonischen Vereinigung zwischen einem Sonnenschirm und einem Segel nimmt eine Synergie zwischen Festigkeit der Materialien und Leichtigkeit der Form Gestalt an. Ein einzigartiger Schirm der die Aussenausstattung aufwertet.

F Le parasol Vela redéfinit le concept et l'architecture de l'ombre, insolite et non conventionnelle. La conception de la couverture évolue en s'inspirant de la mer et façonné par le vent, ce qui entraîne des lignes sinueuses et ergonomique. De la fusion harmonieuse entre un parasol et une voile né une synergie entre la résistance des matériaux et la légèreté de la forme. Un article unique pour améliorer votre environnement extérieur.

E El Parasol Vela redefine el concepto y la arquitectura de la sombra, nuevo y poco convencional. El diseño del tejido evoluciona inspirándose en el mar y las formas que toma el viento, consiguiendo líneas sinuosas y ergonómicas. De la unión armónica entre un parasol y una vela, nace una sinergia entre la resistencia de los materiales y la ligereza de las formas, un objeto único para mejorar su ambiente al aire libre.

NL De parasol VELA geeft het begrip schaduw anders weer, ongewoon en onconventioneel. De vormgever van het doek liet zich inspireren door de zee en de wind. Het resultaat is ergonomisch met strakke lijnen. Door de harmonieuze samenvoeging van een parasol en een zeil ontstaat een synergie tussen stabiliteit van materialen en luchtigheid van de vormgeving. Een unieke parasol, die een grote bijdrage levert aan de uitstraling van ieder terras.





## Galileo Inox **New**



I Il modello Galileo Retrattile, già molto apprezzato per gli accorgimenti tecnici e per la praticità di utilizzo, è ora disponibile anche con il telaio verniciato a polveri in colore Inox.  
Il Galileo Inox si distingue per il design accattivante e moderno.

UK The model Galileo Retractable, much appreciated for the technical and practical use, is now also available with the frame powder coated in inox grey. The model Galileo Inox stands out for the attractive and modern design.

D Das Modell Galileo Retractable, bisher insbesondere fuer den technischen und praktischen Einsatz geschätzt, ist nun auch mit pulverbeschichtetem Gestell in Farbe Inox grau erhaeltlich.  
Attraktives und modernes Design kennzeichnen das Model Galileo Inox.

F Le modèle rétractable Galileo, très apprécié pour l'utilisation technique et pratique, est désormais disponible aussi avec l'armature vernis en couleurs gris inox.  
Le model Galileo Inox se distingue par son design attrayant et moderne.

E El modelo galileo retrattile, es muy apreciado por los datos tecnicos y por ser muy practico en su uso, y ahora tambien esta disponible con la estructura recubierta con pintura en polvo en color gris Inox. El modelo Galileo Inox se distingue por su diseño atractivo y moderno.

NL Het model Galileo Retrattile, befaamd vanwege het technische en praktische gebruiksgemak, is nu ook verkrijgbaar in grijs inox geepoxeerde uitvoering.  
Het model Galileo Inox opvalt voor het aantrekkelijk en modern design.





## Galileo White



I Il modello Galileo Retrattile, già molto apprezzato per gli accorgimenti tecnici e per la praticità di utilizzo, è ora disponibile anche con il telaio verniciato a polveri in colore bianco. Questa variante rende il Galileo White ancora più elegante e sofisticato.

UK The model Galileo Retractable, much appreciated for the technical and practical use, is now also available with the frame powder coated in white. This variant makes the Galileo White even more elegant and sophisticated.

D Das Modell Galileo Retractable, bisher insbesondere fuer den technischen und praktischen Einsatz geschätzt, ist nun auch mit pulverbeschichtetem Gestell in Farbe weiß erhältlich. Diese Variante macht Galileo White noch eleganter und raffinierter.

F Le modèle rétractable Galileo, très apprécié pour l'utilisation technique et pratique, est désormais disponible aussi avec l'armature vernis en couleur blanche. Cette variante rend le Galileo White encore plus élégant et sophistiqué.

E El modelo galileo retrattile, es muy apreciado por los datos tecnicos y por ser muy practico en su uso, y ahora tambien esta disponible con la estructura recubierta con pintura en polvo en color blanco. Esta variante hace al galileo blanco aun mas elegante y sofisticado.

NL Het model Galileo Retrattile, befaamd vanwege het technische en praktische gebruiksgemak, is nu ook verkrijgbaar in wit geëpoxeerde uitvoering. De uitvoering Galileo White is daardoor nog eleganter en chiquer.





## Galileo Dark



- I** Nuovo modello con sistema di apertura retrattile permette la facile chiusura dell'ombrellone anche in presenza di arredo. Si tratta del migliore sistema presente nel mercato perché Scolaro, nel progettare e sviluppare ha tenuto conto di: apertura e inclinazione facilitata, estetica, molta attenzione nel prevedere eventuale assistenza o facile riparazione anche ad opera dell'utente finale. Il sistema di inclinazione progettato indipendente dall'apertura e chiusura rende questo modello la migliore soluzione presente nel mercato.
- UK** New model with opening system close on the support that allows an easy closing of the parasol without moving the furniture. It's the best system on the market that Scolaro has developed considering: functionality of the system, aesthetics, special attention in foreseeing a possible assistance or easy restore by the final customer. The inclination system is planned independently from the opening and closing and makes therefore this model the best solution in the market.
- D** Neues Model mit einziehbarem Öffnungssystem oberhalb von Tischen und Stuehlen. Scolaro hat dieses einzigartige System auf dem Markt entwickelt und besondere Beachtung auf folgende Punkte geschenkt: Funktionalitaet des Systems, Aesthetik, spezielle Aufmerksamkeit fuer eventuelle einfache Ersetze seitens des Endverbrauchers. Einzigartiges Model auf dem Markt, dank der unabhagigen Neigung vom Öffnungs- und Schließungssystem.
- F** Nouveau modèle avec système rétractile au-dessus des tables et chaises. Il s'agit du meilleur système développé sur le marché par Scolaro en tenant compte: du caractère fonctionnel, de l'esthétique, et d'une attention spéciale pour une éventuelle assistance et réparation de la part de l'utilisateur final. Le système d'inclinaison conçu indépendamment de l'ouverture et de la fermeture rend ce modèle la meilleure solution sur le marché.
- E** El nuevo modelo con sistema de apertura retráctil, permite el cierre fácil de la sombrilla, sin mover el mueble. Este es el mejor sistema del mercado que Scolaro ha desarrollado teniendo en cuenta: Funcionalidad del sistema, Estética, Atención especial al prever una posible asistencia o fácil reparación por el cliente final. El sistema de inclinación diseñado independientemente del de apertura y cierre, hace que éste modelo sea la mejor solución presente en el mercado.
- NL** Nieuw systeem voor het openen en sluiten van de zwevende parasol, zonder uw tuinmeubilair daarvoor te moeten verplaatsen. De parasol hoeft nu niet meer verwijderd te worden als u deze niet gebruikt, maar wordt bevestigd aan de mast. Dus geen storende parasol en parasolarm meer boven uw tuinmeubilair als de parasol niet als zodanig gebruikt wordt. Dit unieke systeem is door Scolaro ontwikkeld, waarbij extra aandacht besteed is aan belangrijke punten zoals: Functionaliteit, Vormgeving, Aan het mogelijk vervangen van onderdelen door de consument is extra aandacht besteed. Enige in zijn soort op de parasolmarkt dankzij het onafhankelijke open- en sluitsysteem.





## Galileo Maxi 4x4



I L'ombrellone a braccio laterale con il sistema di chiusura retrattile è ora disponibile anche nella misura 4x4 mt con la struttura ulteriormente irrobustita.

UK The cantilever parasol with retractable closing system is now also available in size 4x4 mt with a further strengthened structure.

D Der Seitenarmschirm mit einziehbarem Schliessungssystem ist nun auch in Grösse 4x4 m erhältlich, mit verstärkter Struktur.

F Le parasol à bras latéral avec système de fermeture rétractable est maintenant également disponible en format 4x4 mt avec la structure renforcée.

E Parasol de brazo lateral y con sistema de cierre ó plegado retráctil. Ahora también disponible en el tamaño de 4 x 4 mts, y con la estructura aún más reforzada.

NL De zwevende parasol, die sluit aan de mast, is nu ook leverbaar in de afmeting 4 x 4 mtr. in een verzwaaarde uitvoering.



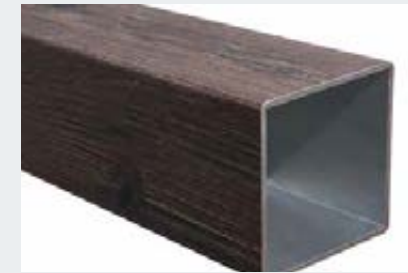
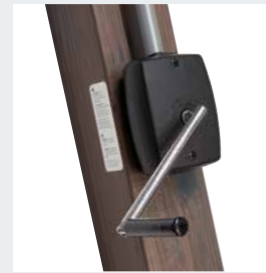

## Giotto Braccio



I Il contrasto di elementi come la finitura color legno Tabacco anticato e i componenti in alluminio color acciaio portano ad un livello superiore la ricerca del lusso. In esclusiva e anteprima Scolaro introduce un nuovo sistema di finitura applicata al sostegno in alluminio con uno speciale rivestimento in colore tabacco anticato che riproduce il legno in 3D.

UK The contrast of elements with wooden tobacco coloured finishing and steel coloured aluminium components lead to a higher level the research of luxury. Scolaro introduces a new finishing applied to the aluminium support with a special coating tobacco antique wood that mimics wood in 3D.

D Der Kontrast der Elemente mit Antique Tobacco Effekt und Alubestandteile Edelstahlfarbig pulverbeschichtet verleihen diesem Model eine besonders luxuriöse Note. Scolaro führt als Erster Alumaeste mit speziellem 3D Holzeffekt Antique Tobacco ein.

F Le contraste des éléments tels que la finition couleur bois tabac antique et des composants en aluminium couleur acier, portent la recherche de luxe à un niveau supérieur. Scolaro a créé une nouvelle finition au niveau du mât en aluminium avec un revêtement spécial effet bois tabac antique en 3D.

E El contraste de elementos como el acabado color madera Tabacco envejecido así como los componentes de aluminio color acero conducen a un nivel superior en cuanto a la búsqueda de lujo. Scolaro introduce un nuevo acabado aplicado sobre el soporte de aluminio con un recubrimiento especial en color Tabacco antiguo que reproduce la madera en 3D.

NL Contrast in materialen: de aluminium mast met tabakskleurige hout-look, de overige aluminium delen [baleinen] geëpoxeerd in een roestvrij staal-look geven dit model een bijzonder luxe uitstraling. Scolaro komt als eerste fabrikant op de markt met een aluminium parasolmast in 3D, die vrijwel niet te onderscheiden is van hout.





Aluminium ribs



Aluminium

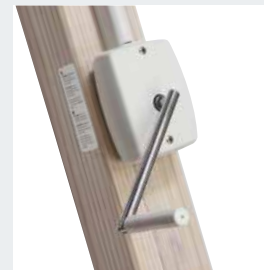

## Milano Braccio **New**



I L'armoniosa combinazione dell'alluminio con finitura frassino sbiancato e i componenti verniciati colore bianco lucido rendono il nuovo Milano Braccio unico per eleganza e riservato agli ambienti più esclusivi. **Nuovo sostegno verticale e stecche previsti in alluminio con speciale finitura effetto frassino sbiancato per un design inalterato nel tempo.**

UK Harmonious combination of aluminium with special bleached ash wood finishing and polish lacquered components make this new item Milano Braccio elegant and suitable for the most exclusive milieux. **New vertical aluminium post and ribs with special ash wood finishing for an unalterable design.**

D Harmonische Kombination von Aluminium mit Eschenholzeffekt und weiss pulverbeschichtete Bestandteile. Neues elegantes Model besonders fuer exclusive Milieux geeignet. **Neuer Alumast und -Streben mit spezial-Eschenholzeffekt verleihen diesem Model ein unveraenderliches Design.**

F Harmonieuse combinaison de aluminium avec finition bois de frene et composants vernis blanc que nous utilisons pour ce nouveau parasol Milano Braccio, un modèle adapté pour les milieu les plus raffinés. **Nouvelle mat vertical et baleines en aluminium avec effet bois de frene permettant un design inchangé.**

E Armoniosa combinacion de aluminio ycon acabado especial en imitacion madera color ceniza blanqueda y componentes recubierti de polvo blanco, hacen de este nuevo articulo un modelo elegante y apropiado para los ambientes ma exclusivos. **El nuevo soporte vertical y las varillas fabricadi en aluminio ycon acabado especial en imitacion madera color ceniza blanqueda, hace que este diseno sea inalterable en el tiempo.**

NL Harmonieuze combinatie van aluminium met uniek essenhouten uitstraling en wit geepoxeerde componenten. Nieuw elegant model. Zeer geschikt voor exclusieve locaties. **Nu met nieuwe aluminium mast en baleinen met uniek essenhouten uitstraling. Ontwerp ongewijzigd in de tijd.**





C4040 LEB

# Leonardo Braccio



- |   |  |   |  |   |  |
|---|--|---|--|---|--|
| <p>I Rinnovato modello completamente in acciaio e alluminio verniciati a polveri epossidiche grigio antracite. Ombrellone particolarmente robusto e adatto per uso professionale.</p> | <p>UK Renewed model completely in steel and aluminium epoxy lacquered. Particularly strong parasol suitable for a professional employ.</p> | <p>D Erneueres Model ganz aus pulverbeschichtetem Stahl und Aluminium. Besonders starker Schirm geeignet fuer einen gewerblichen Einsatz.</p> | <p>F Modèle complètement retravaillé en acier et aluminium avec vernis époxy. Parasol particulièrement robuste et adapté pour une utilisation professionnelle.</p> | <p>E Modelo completamente renovado en acero y aluminio lacado. Sombrilla particularmente fuerte, apropiada para usos profesionales.</p> | <p>NL Vernieuwd model, geheel gefabriceerd uit geëpoxeerd staal en aluminium. Een ideale parasol voor intensief gebruik (waaronder de horeca).</p> |
|---|--|---|--|---|--|





Wooden ribs



Aluminium

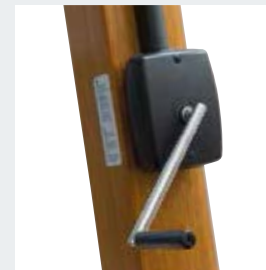

## Palladio Braccio



I Modello di ombrellone prodotto da Scolaro da oltre 20 anni opportunamente aggiornato nel tempo. Dimostra l'ottima progettazione iniziale e riassume la tradizione ed esperienza nel settore, confermato anche dalle migliaia di unità vendute in tutto il mondo. **Nuovo Sostegno verticale previsto in alluminio con speciale finitura effetto legno ancora più robusto e duraturo.**

UK Model produced by Scolaro since over 20 years opportunely renewed. Thousand of pieces sold worldwide, of which many are still employed, are the proof of an optimal planning and that this item sums up tradition and experience in the branch. **New Vertical aluminium support provided with special wood finishing for an unalterable Design.**

D Scolaro stellt dieses Model seit ueber 20 Jahren her und hat es mit der Zeit stets erneuert und verbessert. Die tausenden Teile, die weltweit verkauft wurden und stets noch eingesetzt werden sind der Beweis einer optimalen Planung und der erfolgreichen Kombination von Tradition und Erfahrung in der Branche. **Neuer Alumast mit speziellem Holz Effekt. Unveraenderliches Design.**

F Modèle de parasol fabriqué par Scolaro depuis plus de 20 ans et relooké. Les milliers de pièces vendus dans le monde sont la preuve de la qualité, robustesse et succès que connaît le modèle Palladio et du professionnalisme de la ste Scolaro. **Nouvelle Mat vertical en aluminium avec finition effet bois permettant un design inchangé.**

E Modelo fabricado por Scolaro desde hace 20 años, oportunamente renovado. Se vendieron miles de piezas ( sombrillas) por todo el mundo, de las cuales muchas aún son utilizadas, y esto es la prueba de que este artículo resume la tradición y la experiencia en el sector. **El nuevo soporte vertical fabricado en aluminio con acabados especiales imitación madera, lo hacen más robusto y duradero.**

NL Dit model wordt door Scolaro al meer dan 20 jaar op de markt gebracht en is gedurende die tijd steeds aan de actualiteit aangepast. De vele duizenden die er in de afgelopen jaren wereldwijd verkocht zijn, leveren het bewijs voor uitstekende kwaliteit; dit dankzij de succesvolle combinatie van vakmanschap en ervaring. Aluminium mast met unieke essenhout uitstraling. **Solide zwevende designparasol. Nu met nieuwe aluminium mast met uniek iroko houten uitstraling.**





Aluminium

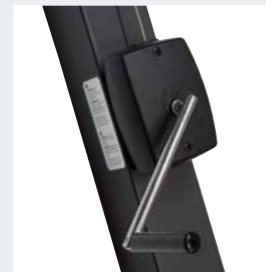

## Napoli Braccio



I La praticità della soluzione a braccio laterale interamente in acciaio e alluminio verniciato antracite mantiene il design raffinato inalterato nel tempo.

UK Handy cantilever parasol entirely made of epoxy lacquered steel and aluminium, keeps its refined design unchanged.

D Praktischer Pendelschirm ganz aus pulverbeschichtetem Stahl und Aluminium. Unveränderliches und raffiniertes Design.

F Parasol pratique avec bras excentré en acier et aluminium vernis qui n'altère en rien le design.

E Práctica sombrilla completamente fabricada en acero y aluminio lacados, reservado para diseños inalterados y refinados.

NL Praktische zwevende parasol geheel in geepoxideerd staal en aluminium. Uniek door zijn geraffineerde vormgeving.



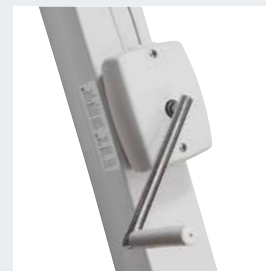

## Rimini Braccio



I Questo modello, rinnovato completamente in acciaio e alluminio verniciati a polveri epossidiche colore bianco, si inserisce perfettamente in ambienti moderni e ricercati.

UK Renewed model completely in steel and aluminium epoxy lacquered colour white. Perfectly fitting with modern and precious milieux.

D Erneueres Model ganz aus pulverbeschichtetem Stahl und Aluminium Farbe weiss. Speziell fuer moderne und besondere Milieux geeignet.

F Modèle complètement relooké en acier et aluminium avec vernis époxy couleur blanc. Parasol particulièrement adapté aux milieux contemporains et raffinés.

E Modelo completamente renovado en acero y aluminio lacado en blanco. Se inserta perfectamente tanto en ambientes modernos como cargados (clásicos, rebuscados).

NL Vernieuwd model, geheel gefabriceerd uit geëpoxeerd staal en aluminium in de kleur wit. Bij uitstek geschikt voor mensen die een luxe en exclusieve parasol zoeken.





Wooden ribs



Aluminium



## Torino Braccio



I Un grande classico caratterizzato dall'impiego del legno. Nuovo sostegno in alluminio con finitura legno che ne migliora le prestazioni senza alterarne l'estetica.

UK A great classic characterized by the employ of wood. New aluminium support with wood finishing that improves the performance without altering the aesthetics.

D Ein grosser Klassiker aus Holz. Der neue Alumast mit Holzeffekt verbessert die Leistung ohne die Aesthetik des Schirmes zu veraendern.

F Un grand classique caractérisé par l'utilisation du bois. Nouveau mât en aluminium avec une belle finition bois qui améliore les qualités du parasol sans en altérer l'esthétique et le design

E Un gran clásico caracterizado por el uso de la madera. Nuevo soporte de aluminio con acabado de madera que mejora el rendimiento sin alterar la estética.

NL Een houten klassieker. De nieuwe aluminium mast met hout-look verbeterd de kwaliteit zonder dat die de uitstraling van de parasol verandert.





Aluminium ribs

## Milano Standard **New**



- I Il nome comunica tutto il significato di un prodotto realizzato in Italia: sapiente esempio di qualità e design con il risultato di un'eleganza unica. **Stecche in alluminio con speciale finitura effetto frassino sbiancato e palo in alluminio verniciato a polveri colore bianco per un design inalterato nel tempo.**
- UK The name transmits the meaning of this item realized in Italy: Wise example of quality, design and elegance. **Aluminium ribs with special bleached ash wood finishing and white epoxy coated aluminium pole for an unalterable design.**
- D Der Name uebertraegt die Eigenschaften dieses Modells italienischer Herstellung: Vorbild von Qualitaet, Design und Eleganz. **Aluminiumstreben mit spezial-Eschenholzeffekt und weissem pulverbeschichtetem Alumittelmast verleihen diesem Model ein unveraenderliches Design.**
- F Le nom traduit le sens du produit réalisé en Italie: Modèle de qualité, design et élégance. **Baleines en aluminium avec effet bois de frene et mat central en aluminium vernis blanc permettant un design inchangé.**
- E Su nombre transmite lo que quiere decir este artículo fabricado en Italia: Claro ejemplo de calidad, diseño y elegancia. **Varillas en aluminio y con acabado especial en imitación madera color ceniza blanqueda y poste central recubierto de polvo blanco, hace que este diseño sea inalterable en el tiempo.**
- NL De naam is synoniem aan de eigenschappen van deze Italiaanse parasol. Toonbeeld van kwaliteit, design en elegantie. **Baleinen van aluminium met uniek essenhouten uitstraling en wit geepoxeerde centrale pole. Ontwerp ongewijzigd in de tijd.**



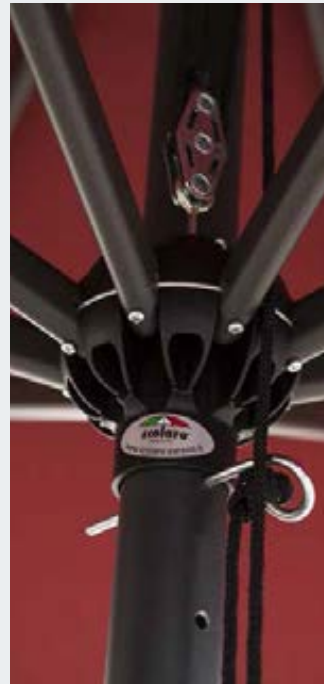

## Napoli Standard



I Combinazione del telaio in alluminio antracite con la semplicità delle linee per un connubio perfetto tra resistenza ed eleganza.

UK Combination of an aluminium frame colour anthracite grey and the simplicity of its lines. Perfect union between resistance and elegance.

D Alugestell in Farbe Anthrazitgrau und schlichte Linien sind die perfekte Verbindung zwischen Widerstandsfähigkeit und Eleganz.

F Armature en aluminium couleur gris anthracite avec des lignes pures. Harmonieuse combinaison de résistance et d'élégance.

E Combinación con marco de aluminio en color antracita y líneas sencillas. Perfecta unión entre resistencia y elegancia.

NL Combinatie van antraciet grijs aluminium frame en eenvoud in belijning. Een perfecte balans tussen degelijkheid en styling.





## Palladio Standard



I Modello storico, presente nella gamma Scolaro da più di 30 anni. La linea classica, ma allo stesso tempo semplice ed essenziale lo rendono adatto a tutti gli ambienti e inattaccabile da tendenze di moda. Prodotto più venduto e diffuso. Ampia gamma e varianti disponibili.

UK Historical model belonging to the Scolaro range since over 30 years. Classic line, but at the same time simply and essential, always in fashion and therefore suitable for all milieux. The most sold item. Wide range of sizes and variants.

D Historisches Model, in der Scolaro Kollektion seit ueber 30 Jahren. Klassisch, einfach, fuer alle Milieux geeignet und stets modern. Meistverkaufter Artikel. Umfangreiche Auswahl an Masse und Varianten.

F Modèle historique, parasol de la collection Scolaro depuis plus de 30 ans. Ligne classique et élégante. Adapté pour tous les milieux. Le modèle le plus vendu. Large gamme avec variantes disponibles.

E Modelo histórico perteneciente a Scolaro desde hace 30 años. Línea clásica, pero al mismo tiempo simple y esencial, siempre moderna y por lo tanto adecuado para todos los ambientes. Es el artículo más vendido. Con amplia gama de tamaños y variantes.

NL Al meer dan 30 jaar de topper in het SCOLARO assortiment. Klassiek, strak en toch steeds modern. Geschikt voor vele locaties. Het meest verkochte model. Een breed assortiment in vele maten en kleuren.





## Leonardo Telescopic



I Il sistema telescopico che permette l'apertura e la chiusura al di sopra di tavoli e sedie abbinato al telaio in alluminio rendono l'ombrellone Leonardo Telescopic resistente, leggero e di facile utilizzo.

UK The telescopic opening system over tables and chairs combined with the employ of an aluminium frame grant strength, lightness and easy employ.

D Das teleskopische Oeffnungssystem oberhalb von Tischen und Stuehlen und das Aluminiumgestell machen aus diesem Schirm eine leichte jedoch starke und fuer einen gewerblichen Einsatz geeignete Version.

F L'ouverture telescopique au-dessus de tables et chaises font de ce article un parasol résistant, léger et apte pour un emploi professionnel.

E El sistema telescópico permite abrir y cerrar el parasol por encima de las mesas siendo de este modo un parasol resistente, ligero y de fácil uso.

NL Dankzij het telescopsysteem is het ook mogelijk bij grotere afmetingen parasols deze te sluiten boven de tafel. Zeer geschikt voor professioneel gebruik.





## Palladio Telescopic



I La versione telescopica, progettata e sviluppata per prima da Scolari, propone una apertura e chiusura dell'ombrellone facile e funzionale al di sopra di tavoli e sedie.

UK The telescopic version Palladio, planned and developed first by Scolari, offers an easy and functional opening and closing over tables and chairs

D Die Teleskopversion Palladio, die Scolari als Erster entwickelt und angeboten hat, bietet eine einfache und funktionelle Öffnung und Schliessung oberhalb von Tischen und Stuehlen an.

F La ligne Palladio télescopique, que Scolari a projeté et développé par premier, offre une ouverture et fermeture facile et fonctionnel.

E La versión telescópica, planeada y desarrollada por la primera vez de Scolari, propone una apertura y un cierre de la sombrilla fácil y funcional por encima de mesas y sillas.

NL De telescoopversie, die Scolari als eerste ontwikkeld heeft, biedt een eenvoudige oplossing om ook grote parasols (Ø 5,00 mtr.) boven de tafel te laten sluiten.



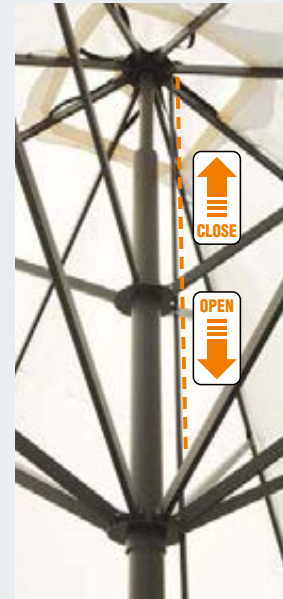

# Capri



I La linea Capri presenta l'ombrellone in alluminio progettato per coprire grandi superfici con il minimo ingombro. La robustezza dei materiali e dei componenti e il sistema di apertura telescopico lo rende di facile utilizzo e ideale per un uso professionale.

UK The aluminium range Capri is projected to cover big surfaces taking the minimum space. The strength of the materials and components and the telescopic opening system allow an easy and professional employ.

D Die Version Capri aus Aluminium ist fuer grosse Flaechen geeignet. Die Staerke der Materialien und der Bestandteile und das teleskopische Oeffnungssystem eignen sich insbesondere fuer einen gewerblichen Einsatz.

F La ligne Capri en aluminium est étudiée pour couvrir de grandes surfaces avec un encombrement minimum. La robustesse des matériaux et des composants, l'ouverture telescopique rendent ce parasol apte pour un emploi facile et professionnel.

E La línea CAPRI en aluminio esta concebido para cubrir grandes superficies ocupando el mínimo espacio. La resistencia de los materiales y de sus componentes, además de un moderno sistema de abertura telescópica, permite a este parasol, tener una utilización sencilla y profesional.

NL CAPRI: een parasol met een aluminium frame en bij uitstek geschikt voor het overkappen van grotere terrassen. De teleskoop uitvoering maakt deze parasol ook zeer geschikt voor professioneel gebruik.





Aluminium

## Milano Poker/Double

I Struttura modulare composta da 2 (Double) o 4 (Poker) ombrelloni ancorati ad un unico sostegno studiata per la copertura di ampie superfici con il minimo ingombro.  
**Ora disponibile con nuovo sostegno verticale e stecche in alluminio con speciale finitura effetto frassino sbiancato per un design inalterato nel tempo.**

UK Structure made of 2 (Double) or 4 (Poker) parasols fixed at the same pole, suitable for big surfaces and minimum encumbrance.  
**Now available with new vertical aluminium post and ribs with special ash wood finishing for an unalterable design.**

D Struktur mit 2 (Double) oder 4 (Poker) Schirmen, die am selben Mast befestigt sind. Raumsparend und fuer grosse Flaechen geeignet.  
**Nun mit Alumast und -Streben mit spezial-Eschenholzeffekt erhaeltlich, die diesem Model ein unveraenderliches Design verleihen.**

F Structure avec 2 (Double) ou 4 (Poker) parasols fixés à un mat. Pour grandes surfaces avec encombrement minimum.  
**Maintenant disponible avec nouvelle mat vertical et baleines en aluminium avec effet bois de frêne qui permettant un design inchangé.**

E Estructura modular compuesta por 2(doble) o 4 (poker) parasoles unidos por un solo mástil, muy adecuado para amplias superficies con poco espacio.  
**Ahora disponible con nuevo soporte vertical y les varillas fabricadi en aluminio ycon acabado especial en imitacion maderas color ceniza blanqueda, que hace que este diseno sea inalterable en el tiempo.**

NL Parasolmast met 2 (Double) of 4 (Poker) parasols. Deze parasols (Double ca. 25 m<sup>2</sup> en Poker ca. 50 m<sup>2</sup>) zijn aan 1 mast bevestigd. Zijn daardoor ruimtebesparend en zeer geschikt voor grotere oppervlakten en terrassen.  
**Nu verkrijgbaar met nieuwe aluminium mast en baleinen met uniek essenhouten uitstraling.**







Aluminium



## Alu Poker/Double

I Struttura modulare in alluminio composta da 2 (Double) o 4 (Poker) ombrelloni ancorati ad un unico sostegno studiata per la copertura di ampie superfici con il minimo ingombro.

UK Aluminium structure made of 2 (Double) or 4 (Poker) parasols fixed at the same pole, suitable for big surfaces and minimum encumbrance.

D Alustruktur mit 2 (Double) oder 4 (Poker) Schirmen, die am selben Mast befestigt sind. Raumsparend und fuer grosse Flaechen geeignet.

F Structure en aluminium avec 2 (Double) ou 4 (Poker) parasols fixés à un mat. Pour grandes surfaces avec encombrement minimum.

E Estructura modular de aluminio compuesta por 2(doble) o 4 (poker) parasoles unidos por un solo mástil, muy adecuado para amplias superficies con poco espacio.

NL Parasolmast met 2 (Double) of 4 (Poker) parasols. Deze parasols (Double ca. 25 m<sup>2</sup> en Poker ca. 50 m<sup>2</sup>) zijn aan 1 mast bevestigd. Zijn daardoor ruimtebesparend en zeer geschikt voor grotere oppervlakten en terrassen.







## Wood Poker/Double **New**



- I Struttura modulare in legno composta da 2 (Double) o 4 (Poker) ombrelloni ancorati ad un unico sostegno studiata per la copertura di ampie superfici con il minimo ingombro. **Ora disponibile con nuovo sostegno verticale in alluminio con speciale finitura effetto Iroko e stecche in legno Iroko.**
- UK Wooden structure made of 2 (Double) or 4 (Poker) parasols fixed at the same pole, suitable for big surfaces and minimum encumbrance. **Now available with new vertical aluminium post with special Iroko wood finishing and ribs made of Iroko wood.**
- D Holzstruktur mit 2 (Double) oder 4 (Poker) Schirmen, die am selben Mast befestigt sind. Raumsparend und fuer grosse Flaechen geeignet. **Nun mit Alumast mit IrokoHolzeffekt und Streben aus IrokoHolz erhaeltlich.**
- F Structure en bois avec 2 (Double) ou 4 (Poker) parasols fixés à un mat. Pour grandes surfaces avec encombrement minimum. **Maintenant disponible avec nouvelle mat vertical en aluminium avec effet bois Iroko et baleines en bois Iroko.**
- E Estructura modular de madera compuesta por 2(doble) o 4 (poker) parasoles unidos por un solo mástil, muy adecuado para amplias superficies con poco espacio. **Ahora disponible con nuevo soporte vertical en aluminio y con acabado especial en imitación madera Iroko y varillas en madera Iroko.**
- NL Parasolmast met 2 (Double) of 4 (Poker) parasols. Deze parasols (Double ca. 25 m<sup>2</sup> en Poker ca. 50 m<sup>2</sup>) zijn aan 1 mast bevestigd. Zijn daardoor ruimtebesparend en zeer geschikt voor grotere oppervlakten en terrassen. **Nu verkrijgbaar met nieuwe aluminium mast met uniek Iroko uitstraling. Iroko houtten baleinen.**

# Bases



## BT45 - BT55 - BT65

- Tubo in acciaio zincato. Doppio galletto. Viteria inclusa.
- Steel zined tube. Double wing nut. Screws included.
- Verzinkte Stahlhülse. Doppelte Hutmutter. Schrauben inbegriffen.
- Tube acier zingué. Avec écru papillon. Visserie incl.
- Tubo de acero galvanizado. Los tornillos incluidos.
- Koker gegalvaniseerd. Inclusief schroeven.

	COD				KG
-	<b>BT45</b>	42 mm	45 mm	36-40 mm	1
-	<b>BT55</b>	52 mm	55 mm	47-50 mm	1
-	<b>BT65</b>	62 mm	65 mm	55-60 mm	1



## BTT55 - BTT65

- Tubo acciaio per fissaggio a terra. Eventualmente da abbinare all'articolo BTC.
- Steel tube for ground fixing. Possibility to combine it with Art BTC.
- Stahlhülse fuer Bodenbefestigung. Eventuell mit Art BTC kombinierbar.
- Tube en acier pour fixation au sol. Eventuellement à joindre avec BTC.
- Tubo de acero para sujeción al suelo. Posiblemente para que coincida con el artículo BTC.
- Metalen koker voor betonanker. Te gebruiken in combinatie met artikel BTC.



## BTC

- Supporto da interrare. Da abbinare a BTT55 e BTT65
- support for ground fixing. To combine with BTT55 and BTT65.
- Staender zum einbetonieren. Kombinierbar mit BTT55 und BTT65.
- Pied pour fixation au sol. A joindre avec BTT55 et BTT65.
- Pie para fijar al suelo. Combinar con BTT55 y BTT65.
- Betonanker, te gebruiken in combinatie met BTT55 en BTT65.

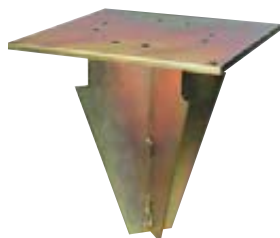
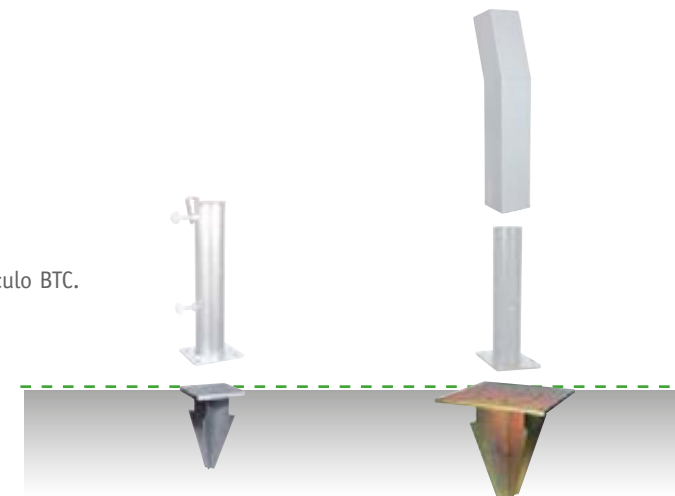

## BTB

- Supporto da interrare. Per ombrelloni a braccio, Poker/Double, Capri.
- support for ground fixing. For cantilever parasols, Poker/Double, Capri.
- Staender zum einbetonieren. Fuer Pendelschirme, Poker/Double, Capri.
- Pied pour fixation au sol. Pour parasols avec bras deporté, Poker/Double, Capri.
- Pie para fijar al suelo. Para parasoles de brazo lateral, Poker/Double, Capri.
- Betonanker voor vrijhangende parasols, Poker/Double, Capri.

	COD				KG
-	<b>BTT55</b>	52 mm	55 mm	47-50 mm	1
-	<b>BTT65</b>	62 mm	65 mm	55-60 mm	1
80x120 mm	<b>BTC</b>	-	-	-	1,5
300x300 mm	<b>BTB</b>	-	-	-	10

# Bases



## BF6565D

- Base in acciaio colore antracite. Spessore 1,5cm. Tubo incl.
- Steel base colour antracite grey. Thickness 1,5cm. Tube incl.
- Stahlstaender grau pulverbeschichtet. Dicke 1,5cm. Huelse inbegriffen.
- Pied en acier vernis coul. gris. Epaisseur 1,5cm. Tube incl.
- Pie de acero de color antracita. 1,5 cm de espesor. Tubo incluido.
- Parasolvoet grijs geëpoxeerde metaalplaat. Dikte 1,5 cm. Wordt geleverd met koker.

650x650 mm	COD				KG
	<b>BF6565D/T45</b>	42 mm	45 mm	36-40 mm	
<b>BF6565D/T55</b>	52 mm	55 mm	47-50 mm		
<b>BF6565D/T65</b>	62 mm	65 mm	55-60 mm		



## BF6666D

- Base in acciaio colore antracite. Spessore 2,5cm. Tubo incl.
- Steel base colour antracite grey. Thickness 2,5cm. Tube incl.
- Stahlstaender grau pulverbeschichtet. Dicke 2,5cm. Huelse inbegriffen.
- Pied en acier vernis coul. gris. Epaisseur 2,5cm. Tube incl.
- Pie de acero color antracita. Espesor de 2,5 cm. Tubo incl.
- Parasolvoet grijs geëpoxeerde metaalplaat. Dikte 2,5 cm. Inclusief grijs geëpoxeerde koker

650x650 mm	COD				KG
	<b>BF6666D/T45</b>	42 mm	45 mm	36-40 mm	
<b>BF6666D/T55</b>	52 mm	55 mm	47-50 mm		
<b>BF6666D/T65</b>	62 mm	65 mm	55-60 mm		



## BF6565Z

- Base in acciaio zincato. Spessore 1,5cm. Tubo incl.
- Zinced steel base. Thickness 1,5cm. Tube incl.
- Verzinkter Stahlstaender. Dicke 1,5cm. Huelse inbegriffen.
- Pied en acier zinqué. Epaisseur 1,5cm. Tube incl.
- Base de acero. 1,5 cm de espesor. Tubo incluido.
- Parasolvoet gegalvaniseerde metaal. Dikte 1,5 cm. Wordt geleverd met koker.

650x650 mm	COD				KG
	<b>BF6565Z/T45</b>	42 mm	45 mm	36-40 mm	
<b>BF6565Z/T55</b>	52 mm	55 mm	47-50 mm		
<b>BF6565Z/T65</b>	62 mm	65 mm	55-60 mm		

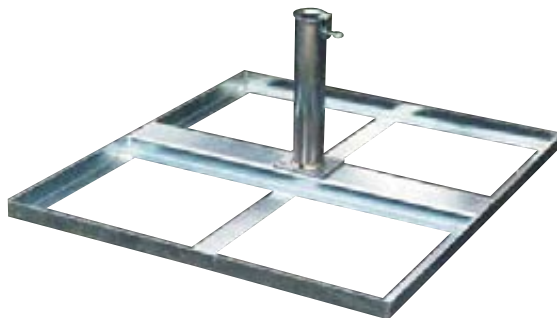

## BLZ

- Base in acciaio. Disponibile con BTT55 e BTT65. Tubo incluso
- Zinced steel base. Available with BTT55 and BTT65. Tube incl.
- Stahlplattenstaender. Verfuegbar mit BTT55 und BTT65. Huelse inbegriffen.
- Pied en acier. Disponible avec BTT55 et BTT65. Tube incl.
- Base de acero. Disponible en BTT55 y BTT65. Tubo incluido.
- Parasolvoet gegalvaniseerde metaal voor betontegels (niet inbegrepen)
- Leverbaar met BTT 55 en BTT 65. Wordt geleverd met koker.

800x950 mm	COD				KG
	<b>BLZ/T55</b>	52 mm	55 mm	47-50 mm	
<b>BLZ/T65</b>	62 mm	65 mm	55-60 mm		

# Bases



## BC35 – BC55

- Base in cemento graniglia. Disponibile con tubo BT45, BT55, BT65 Tubo incluso.
- Cement grit base. Available with tube BT45, BT55, BT65. Tube incl.
- Kiesbetonstaender. Verfüegbar mit Huelse BT45, BT55, BT65. Huelse inbegr.
- Pied ciment grés. Disponible avec tube BT45, BT55, BT65. Tube incl.
- Base de cemento y arena. Disponible con tubo BT45, BT55, BT65. Tubo incluido.
- Parasolvoet gewassen grind. Inclusief koker, maat naar keuze: BT45, BT55, BT65.

	COD				KG
Ø 540 mm	BC35/T45	42 mm	45 mm	36-40 mm	35 kg
	BC35/T55	52 mm	55 mm	47-50 mm	
	BC35/T65	62 mm	65 mm	55-60 mm	
Ø 600 mm	BC55/T45	42 mm	45 mm	36-40 mm	55 kg
	BC55/T55	52 mm	55 mm	47-50 mm	
	BC55/T65	62 mm	65 mm	55-60 mm	



## BC55M - BC80M

- Base in cemento graniglia. Disponibile con tubo BT45, BT55, BT65. Tubo incluso
- Cement grit base. Available with tube BT45, BT55, BT65. Tube incl.
- Kiesbetonstaender. Verfüegbar mit Huelse BT45, BT55, BT65. Huelse inbegr.
- Pied ciment grés. Disponible avec tube BT45, BT55, BT65. Tube incl.
- Base de cemento. Disponible con tubo BT45, BT55, BT65. Tubo incluido.
- Parasolvoet gewassen grind. Inclusief koker, maat naar keuze: BT45, BT55, BT65.

	COD				KG
Ø 600 mm	BC55M/T45	42 mm	45 mm	36-40 mm	55 kg
	BC55M/T55	52 mm	55 mm	47-50 mm	
	BC55M/T65	62 mm	65 mm	55-60 mm	
Ø 640 mm	BC80M/T45	42 mm	45 mm	36-40 mm	80 kg
	BC80M/T55	52 mm	55 mm	47-50 mm	
	BC80M/T65	62 mm	65 mm	55-60 mm	

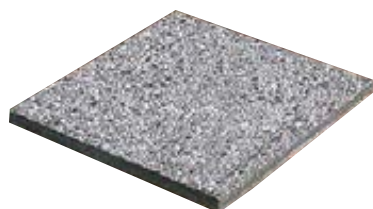

## BC 4040 - BC 5050

- Piastra in cemento e graniglia. Spessore 4cm. Per base Art BLZ (4040). Per ombrelloni a braccio (5050).
- Cement grit slab. Thickness 4cm. For base Art BLZ (4040). For cantilever parasols (5050).
- Kiesbetonplatte. Dicke 4cm. Fuer Staender Art BLZ (4040). Fuer Pendelschirme (5050).
- Dalles ciment et grès. Epaisseur 4cm. Pour pied Art BLZ (4040). Pour parasols avec bras deporté (5050).
- Planchas de hormigón y de grava. De espesor 4 cm. Para base BLZ (4040). Para parasoles con voladizo (5050).
- Gewassen grindtegel. Gewicht 20 kg. Dikte 4 cm. Voor Parasolvoet type BLZ (4040). Voor vrijhangende parasols (5050).

	COD	KG
400X400 mm	BC 4040	14 kg
500X500 mm	BC 5050	20 kg

# Bases



## BC 5151

Piastra in cemento e graniglia con maniglie. Spessore 11cm. Per ombrelloni a braccio.  
 Cement grit slab with handles. Thickness 11cm. For cantilever parasols  
 Kiesbetonplatte mit Handgriffen. Dicke 11cm. Fuer Pendelschirme.  
 Dalles ciment et grès avec poignées. Epaisseur 11cm. Pour parasols avec bras deporté  
 Placas de hormigón y arena con asas. De espesor 11 cm Para parasoles con voladizo.  
 Gewassen grindtegel met handgrepen. Dikte 11 cm. Geschikt voor vrijhangende parasols.

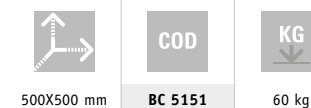

## BC 5151G

Piastra in cemento grigio con maniglie. Spessore 11cm. Per ombrelloni a braccio.  
 Concrete grey cement slab with handles. Thickness 11cm. For cantilever parasols  
 Graue Betonplatte mit Handgriffen. Dicke 11cm. Fuer Pendelschirme.  
 Dalles ciment couleur gris avec poignées. Epaisseur 11cm. Pour parasols avec bras deporté  
 Base de cemento gris con asas. De espesor 11 cm. Para parasoles con voladizo.  
 Betontegel grijs met handgrepen. Dikte 11 cm. Geschikt voor vrijhangende parasols.

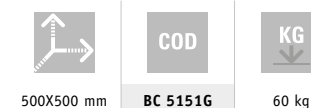

## BV5050G

- Vaso in cemento grigio con maniglie. Per ombrelloni a braccio.
- Concrete grey cement pot with handles. For cantilever parasols.
- Grauer Betontopf mit Handgriffen. Fuer Pendelschirme.
- Vase ciment couleur gris avec poignées. Pour parasols avec bras deporté.
- Maceta de cemento gris con asas. Para parasoles con voladizo.
- Plantenschaal grijs beton met handgrepen. Geschikt voor vrijhangende parasols.



## BV5050B

- Vaso in cemento bianco con maniglie. Per ombrelloni a braccio.
- Concrete white cement pot with handles. For cantilever parasols
- Weisser Betontopf mit Handgriffen. Fuer Pendelschirme.
- Vase ciment couleur blanc avec poignées. Pour parasols avec bras deporté
- Maceta de cerámica con asas de hormigón. Para parasoles con voladizo.
- Plantenschaal beton met handgrepen. Geschikt voor vrijhangende parasols.



### 33. Palladio Standard

I  
Telaio in legno Iroko  
selezionato, trattato con  
vernice protettiva per esterni.

F  
Armature: Bois Iroko  
sélectionné, traité avec un  
vernis protecteur.

UK  
Frame: Selected Iroko wood.  
Varnished and treated.

E  
Estructura: Iroko con  
recubrimientos protectores  
para uso en exteriores.

D  
Gestell: Erstklassiges Irokoholz  
mit umweltfreundlicher  
Schutzlasur.

NL  
Mast en baleinen: Iroko.  
Milieuvriendelijk behandeld.

	COD	MEASURES		CHARACTERISTICS							
				KG							
2,5	C2500 PAS			10	0,09	38	-	IROKO WOOD	6	IROKO WOOD	18x30
3,0	C3000 PAS			17	0,10	48	-	IROKO WOOD	8	IROKO WOOD	18x34
3,5	C3500 PAS			18	0,10	48	-	IROKO WOOD	8	IROKO WOOD	18x34
4,0	C4000 PAS			23	0,17	58	-	IROKO WOOD	8	IROKO WOOD	18x34
2,0x2,0 NEW	C2020 PAS			10	0,09	48	-	IROKO WOOD	4	IROKO WOOD	18x34
3,0x3,0	C3030 PAS			20	0,11	48	-	IROKO WOOD	8	IROKO WOOD	18x34
3,5x3,5	C3535 PAS			25	0,17	58	-	IROKO WOOD	8	IROKO WOOD	18x34
4,0x4,0	C4040 PAS			31	0,17	58	-	IROKO WOOD	8	IROKO WOOD	20x34
2,0x3,0	C2030 PAS			16	0,14	48	-	IROKO WOOD	8	IROKO WOOD	18x34
3,0x4,0	C3040 PAS			26	0,12	58	-	IROKO WOOD	8	IROKO WOOD	18x34

FINISHING				COLOUR RANGE							OPTIONAL			BASES									
				ACRYL 350 GR								GOLD		BC35	BC55 BC55M	BC80M	BF6565D BF6565Z	BF6666D	BLZ	BTT55+BTC BTT65+BTC			
				A1	A1	A2	A3	A6	A7	S1	P2												
●	●	-	-	-		-	-	-	-	-	-		●	●	●			/	/	/	/		
●	●	-	-	-		-	-	-	-	-	-		●	●	●			/	/	/	/		
●	●	-	-	-							-		●	●	●	/				/	/	/	
●	●	-	-	-		-	-	-	-	-	-		●	●	●	/							
●	●	-	●			-	-	-	-	-	-		●	●	●			/	/	/	/		
●	●	-	●										●	●	●	/							
●	●	-	●								-		●	●	●	/							
●	●	-	●								-		●	●	●	/	/		/				
●	●	-	●		-	-	-	-	-	-	-		●	●	●					/	/		
●	●	-	●										●	●	●	/							

## 29. Milano Standard

I

Telaio: Palo in alluminio verniciato a polveri colore bianco. Stecche in alluminio con speciale finitura effetto frassino sbiancato e palo in alluminio verniciato a polveri colore bianco.

F

Armature: Mat en aluminium vernis blanc. Baleines bois frenes bianchi. Baleines en aluminium avec effet bois de frene et mat central en aluminium vernis blanc.

UK

Frame: Aluminium pole, powder coated white. Aluminium ribs with special bleached ash wood finishing and white epoxy coated aluminium pole

E







Estructura: mástil de aluminio recubierto de polvo de color blanco. Varillas de madera de fresno. Varillas en aluminio y con acabado especial en imitacion madera color ceniza blanqueda y poste central recubierto de polvo blanco.

D

Gestell: Mast aus pulverbeschichtetem Aluminium Farbe weiss. Aluminiumstreben mit spezial-Eschenholzeffekt und weisser pulverbeschichteter Alumittelmast.

NL

Mast: aluminium, wit geëpoxeerd. Baleinen van aluminium met uniek essenhouten uitstraling en wit geepoxeerde centrale pole.

	COD	MEASURES		CHARACTERISTICS							
		KG	M <sup>3</sup>								
3,0x3,0	C3030 MIS	19	0,11	55	-	ALU WHITE	8	ALU ASH	18x30		
3,5x3,5	C3535 MIS	22	0,12	55	-	ALU WHITE	8	ALU ASH	18x30		
3,0x4,0	C3040 MIS	22	0,12	55	-	ALU WHITE	8	ALU ASH	18x30		

## 31. Napoli Standard

I

Telaio in alluminio verniciato a polveri colore antracite.

F

Armature: Aluminium vernis couleur gris anthracite.

UK

Frame: aluminium powder coated anthracite grey.

E







Polvo de aluminio recubierto marco de antracita. Accesorios de nylon.

D

Gestell: Pulverbeschichtetes Aluminium Farbe Anthrazitgrau.

NL

Mast en baleinen: aluminium, antracietgrijs geëpoxeerd.

	COD	MEASURES		CHARACTERISTICS							
		KG	M <sup>3</sup>								
3,5	C3500 NAS	14	0,10	50	-	ALU DARK	8	ALU DARK	18x30		
2,0x2,0	C2020 NAS <b>NEW</b>	10	0,09	50	-	ALU DARK	4	ALU DARK	18x30		
3,0x3,0	C3030 NAS	15	0,11	50	-	ALU DARK	8	ALU DARK	18x30		
3,0x4,0	C3040 NA	18	0,12	50	-	ALU DARK	8	ALU DARK	18x30		

FINISHING				COLOUR RANGE							OPTIONAL			BASES						
				ACRYL 350 GR								GOLD		BC35	BC55 BC55M	BC80M	BF6565D BF6565Z	BF6666D	BLZ	BTT55+BTC BTT65+BTC
				A1	A1	A2	A3	A6	A7	S1										
•	•	•	•								•	-	•	/						
•	•	•	•								•	-	•	/						
•	•	•	•								•	-	•	/						

FINISHING				COLOUR RANGE							OPTIONAL			BASES							
				ACRYL 350 GR								GOLD		BC35	BC55 BC55M	BC80M	BF6565D BF6565Z	BF6666D	BLZ	BTT55+BTC BTT65+BTC	
				A1	A1	A2	A3	A6	A7	S1	P2										
•	•	•	-	-							-	•	-	•	/			/	/	/	
•	•	•	•			-	-	-	-	-	-	•	-	•			/	/	/		
•	•	•	•									•	-	•	/						
•	•	•	•									•	-	•	/						

### 37. Palladio Telescopic

I  
Sistema di apertura  
telescopico. Telaio in legno  
Iroko selezionato, trattato con  
vernice protettiva per esterni.

F  
Ouverture telescopique.  
Armature: Bois Iroko  
sélectionné, traité avec un  
vernis protecteur.

UK  
Telescopic opening system.  
Frame: Selected Iroko wood.  
Varnished and treated.

E  
Sistema de apertura  
telescópica. Estructura: Iroko  
con recubrimientos protectores  
para uso en exteriores.

D  
Teleskopoeffnungssystem.  
Gestell: Erstklassiges Irokoholz  
mit umweltfreundlicher  
Schutzlasur.

NL  
Telescoop systeem voor  
het openen en sluiten van  
de parasol boven de tafel.  
Mast en baleinen: Iroko,  
milieuvriendelijk behandeld.

COD		MEASURES		CHARACTERISTICS							
↑	↔	KG	M <sup>3</sup>	⊗	⊕	⊘	⊙	⊚	⊛	⊜	
5,0	C5000 PAT	32	0,21	58	-	IROKO WOOD	10	IROKO WOOD	18x34		
4,0x4,0	C4040 PAT	30	0,23	58	-	IROKO WOOD	8	IROKO WOOD	20x34		
3,0x4,0	C3040 PAT	25	0,15	58	-	IROKO WOOD	8	IROKO WOOD	18x34		

### 35. Leonardo Telescopic

I  
Sistema di apertura  
telescopico. Telaio: Alluminio  
verniciato a polveri colore  
antracite.

F  
Ouverture telescopique  
Armature: Aluminium vernis  
couleur gris anthracite.

UK  
Telescopic opening system.  
Frame: Aluminium powder  
coated anthracite grey.

E  
Sistema de apertura  
telescópica. Mástil: aluminio  
recubierto de color antracita.  
Accesorios de nylon.

D  
Teleskopoeffnungssystem  
Gestell: Pulverbeschichtetes  
Aluminium Farbe  
Anthrazitgrau.

NL  
Telescoop systeem voor het  
openen en sluiten van de  
parasol boven de tafel. Mast  
en baleinen: aluminium,  
antracietgrijs geëpoxeerd.

COD		MEASURES		CHARACTERISTICS							
↑	↔	KG	M <sup>3</sup>	⊗	⊕	⊘	⊙	⊚	⊛	⊜	
4,0x4,0	C4040 LET	25	0,20	55	-	ALU DARK	8	ALU DARK	18x35		

### 39. Capri

I  
Ombrellone gigante. Telaio con  
sistema di apertura telescopico in  
acciaio verniciato a polveri colore  
antracite.

F  
Parasol géant. Ouverture  
telescopique. Armature :  
Aluminium, composants en acier  
vernis couleur gris anthracite.

UK  
Giant parasol. Telescopic opening  
system. Frame: powder coated  
aluminium, steel components  
anthracite grey.

E  
Parasol gigante con sistema  
de apertura telescópica.  
Herrajes: aluminio, componentes  
en acero color gris antracita.

D  
Riesenschirm.  
Teleskopoeffnungssystem Gestell:  
Pulverbeschichtetes Aluminium  
Farbe Anthrazitgrau, Bestandteile  
aus Stahl.

NL  
Maxi parasol: Telescoop systeem,  
voor het openen en sluiten van  
de parasol boven de tafel. Mast  
en baleinen: Grijs geëpoxeerd  
aluminium en staal.

COD		MEASURES		CHARACTERISTICS							
↑	↔	KG	M <sup>3</sup>	⊗	⊕	⊘	⊙	⊚	⊛	⊜	
5,0x5,0	C5050 CAT	130	0,80	100	-	ALU DARK	8	ALU DARK	20x40		
5,0x6,0 NEW	C5060 CAT	140	0,90	100	-	ALU DARK	8	ALU DARK	20x40		
6,0x6,0	C6060 CAT	150	0,90	100	-	ALU DARK	8	ALU DARK	20x40		

FINISHING					COLOUR RANGE							OPTIONAL			BASES						
					ACRYL 350 GR								GOLD		BC35	BC55 BC55M	BC80M	BF6565D BF6565Z	BF6666D	BLZ	BTT55+BTC BTT65+BTC
					A1	A1	A2	A3	A6	A7	S1										
•	•	-	•	-	-		-	-	-	-	-	•	•	•	/	/		/			
•	•	-	•	•								•	•	•	/	/		/			
•	•	-	•	•								•	•	•	/						

FINISHING					COLOUR RANGE							OPTIONAL			BASES						
					ACRYL 350 GR								GOLD		BC35	BC55 BC55M	BC80M	BF6565D BF6565Z	BF6666D	BLZ	BTT55+BTC BTT65+BTC
					A1	A1	A2	A3	A6	A7	S1										
•	•	•	•	•								•	-	•	/	/		/			

FINISHING					COLOUR RANGE		OPTIONAL		BASES				
				INOX	ACRYL 350 GR				N°2 BC5151 N°6 BC5050	N°4 BC5151 N°12 BC5050	N°2 BV5050	N°4 BV5050	FISSAGGIO TERRA INGROUND FIX
					A1	A1							
•	•	•	•	•			•	•	/		/		
•	•	•	•	•			•	•	/		/		
•	•	•	•	•			•	•	/		/		

## 19. Leonardo Braccio

I  
Ombrellone a braccio laterale robusto. Telaio: Alluminio e componenti in acciaio; verniciato a polveri colore antracite. Accessori in nylon.

F  
Parasol bras deporté robuste. Armature: Aluminium vernis couleur gris anthracite. Accessoires en nylon.

UK  
Strong cantilever parasol. Frame: Powder coated aluminium anthracite grey. Nylon accessories.

E  
Brazo lateral resistente. Estructura: aluminio y piezas de acero, recubierto con polvo de antracita. Accesorios de nylon.

D  
Starker Pendelschirm. Gestell aus pulverbeschichtetem Aluminium Farbe Anthrazitgrau. Zubehoer aus Nylon.

NL  
Robuuste vrijhangende parasol. Mast en baleinen: grijs geëpoxeerd aluminium en staal.

↑ ↔ ↓	COD	MEASURES		CHARACTERISTICS						
		KG	M <sup>3</sup>							
4,0	C4000 LEB	68	0,35	92x92	ALU DARK	8	ALU DARK	18x30		
3,0x3,0	C3030 LEB	68	0,35	92x92	ALU DARK	8	ALU DARK	18x30		
3,5x3,5	C3535 LEB	70	0,36	92x92	ALU DARK	8	ALU DARK	18x30		
4,0x4,0	C4040 LEB	100	0,48	92x92	ALU DARK	8	ALU DARK	18x35		
3,0x4,0	C3040 LEB	70	0,36	92x92	ALU DARK	8	ALU DARK	18x30		

## 23. Napoli Braccio

I  
Ombrellone a braccio laterale. Telaio in alluminio e componenti in acciaio; verniciato a polveri colore antracite. Accessori in nylon.

F  
Parasol bras deporté. Armature en aluminium vernis, composants en acier couleur gris anthracite. Accessoires en nylon.

UK  
Cantilever parasol. Frame: Powder coated aluminium anthracite grey. Nylon accessories.

E  
Parasol de brazo lateral. Herraje: aluminio y componentes de acero, recubierto con polvo de antracita. Accesorios de nylon.

D  
Pendelschirm. Gestell aus pulverbeschichtetem Aluminium und Bestandteile aus Stahl Farbe Anthrazitgrau. Zubehoer aus Nylon.

NL  
Vrijhangende parasol. Mast en baleinen: grijs geëpoxeerd aluminium en staal.

3,0x3,0	C3030 NAB	50	0,20	75x75	ALU DARK	8	ALU DARK	18x30
2,0x3,0	C2030 NAB	48	0,20	75x75	ALU DARK	8	ALU DARK	18x30
	C3020 NAB							
3,0x4,0	C3040 NAB	52	0,21	75x75	ALU DARK	8	ALU DARK	18x30

FINISHING									COLOUR RANGE							OPTIONAL		BASES				
									ACRYL 350 GR									N°2 BC5151 N°6 BC5050	N°4 BC5151 N°12 BC5050	N°2 BV5050	N°4 BV5050	FISSAGGIO TERRA INGROUND FIX
									A1	A1	A2	A3	A6	A7	S1							
•	•	•	•	•	•	•	•	•	-		-	-	-	-	-	•	•	/		/		
•	•	•	•	•	•	•	•	•								•	•				/	
•	•	•	•	•	•	•	•	•								•	•				/	
•	•	•	•	•	•	•	•	•								•	•	/		/		
•	•	•	•	•	•	•	•	•								•	•				/	
•	•	•	•	•	•	•	•	•									•	•				
•	•	•	•	•	•	•	•	•		-	-	-	-	-	-	-	•	•				
•	•	•	•	•	•	•	•	•									•	•				

### 13. Galileo Maxi 4x4

I  
Ombrellone a braccio laterale con sistema di apertura e chiusura retrattile. Telaio: Alluminio e componenti in acciaio; verniciato a polveri colore antracite. Accessori in nylon.

F  
Parasol bras deporté avec système retractile. Armature :Aluminium vernis couleur gris anthracite. Accessoires en nylon.

UK  
Cantilever parasol with retractable opening and closing. Frame: powder coated aluminium anthracite grey. Nylon accessories.

E  
Parasol de brazo lateral con sistema con la apertura y cierre retráctil. Herraje: Aluminio y acero, recubierto con polvo de antracita. Accesorios de nylon.

D  
Pendelschirm mit einziehbarem Öffnungssystem. Gestell: Pulverbeschichtetes Aluminium Farbe Anthrazitgrau. Zubehoer aus Nylon.

NL  
Vrijhangende parasol. Frame: grijs geëpoxeerd aluminium en staal f. wit.

COD		MEASURES		CHARACTERISTICS							
4x4	DARK C4040 GDR										
		4000	4700	110	0,55	-	92x92	ALU DARK	8	ALU DARK	18x35

### 06/08/10. Galileo White/Dark/Inox New

I  
Ombrellone a braccio laterale con sistema di apertura e chiusura retrattile. Telaio: Alluminio e componenti in acciaio; verniciato a polveri colore antracite, bianco, inox. Accessori in nylon.

F  
Parasol bras deporté avec système retractile. Armature: Aluminium vernis couleur gris anthracite, blanche, inox. Accessoires en nylon.

UK  
Cantilever parasol with retractable opening and closing. Frame: powder coated aluminium anthracite grey, white, inox. Nylon accessories.

E  
Parasol de brazo lateral con sistema con la apertura y cierre retráctil. Herraje: Aluminio recubierto con polvo de antracita, blanco, inox. Accesorios de nylon.

D  
Pendelschirm mit einziehbarem Öffnungssystem. Gestell: Pulverbeschichtetes Aluminium pulverbeschichtet Farbe Anthrazitgrau, Weiss, Inox. Zubehoer aus Nylon.

NL  
Vrijhangende parasol. Frame: Donker grijs, wit, inox geepoxeerd aluminium.

COD		MEASURES		CHARACTERISTICS							
3,0x3,0	DARK C3030 GDR			65	0,45	-	82x82	ALU DARK	8	ALU DARK	18x30
	WHITE C3030 GWR							ALU WHITE			
	INOX C3030 GIR							ALU INOX			
3,5x3,5	DARK C3535 GDR			75	0,45	-	82x82	ALU DARK	8	ALU DARK	18x30
	WHITE C3535 GWR							ALU WHITE			
	INOX C3535 GIR							ALU INOX			
3,0x4,0	DARK C3040 GDR			75	0,45	-	82x82	ALU DARK	8	ALU DARK	18x30
	WHITE C3040 GWR							ALU WHITE			
	INOX C3040 GIR							ALU INOX			

FINISHING								COLOUR RANGE							OPTIONAL		BASES			
								ACRYL 350 GR									N°2 BC5151 N°6 BC5050	N°4 BC5151 N°12 BC5050	N°4 BV5050	FISSAGGIO TERRA INGROUND FIX
•	•	•	•	•	•	•	•								•	•	/			

FINISHING								COLOUR RANGE							OPTIONAL		BASES			
								ACRYL 350 GR									N°2 BC5151 N°6 BC5050	N°4 BC5151 N°12 BC5050	N°2 BV5050	FISSAGGIO TERRA INGROUND FIX
•	•	•	•	•	•	•	•								•	•	/			
•	•	•	•	•	•	•	•								•	•	/			
•	•	•	•	•	•	•	•								•	•	/			

## 15. Giotto Braccio

I  
Ombrellone a braccio laterale robusto. Telaio in alluminio e componenti in acciaio colore inox. Sostegno rivestito con finitura tabacco anticato.

F  
Parasol bras deporté. Armature en aluminium vernis couleur inox. Composants en aluminium et acier vernis couleur inox. Mat avec finition effet bois tabac antique.

UK  
Strong cantilever parasol. Aluminium frame powder coated colour inox. Steel components. Support with tobacco antique finishing.

E  
Parasol con brazo lateral robusto. Herrajes en aluminio y componentes en acero color inox. Soporte con acabado Tobacco antiguo.

D  
Starker Pendelschirm. Gestell aus Aluminium und Stahlbestandteile pulverbeschichtet Farbe Edelstahl. Mast mit neuer Holzeffekt-Ausführung Antique Tobacco.

NL  
Solide vrijhangende parasol. Aluminium frame met metalen delen met roestvrij staal-look Aluminium mast met hout-look. Kleur antique tobacco.

## 17. Milano Braccio New

I  
Ombrellone a braccio laterale robusto. Nuovo sostegno verticale e stecche in alluminio con speciale finitura effetto frassino sbiancato, componenti in alluminio e acciaio verniciato a polveri colore bianco.

F  
Parasol à bras latra robuste. Avec nouvelle mat vertical et baleines en aluminium avec effet bois de frene. Composants en aluminium et en acier laqué blanc.

UK  
Strong cantilever parasol. New vertical aluminium post and ribs with special ash wood finishing. Aluminium and steel components, epoxy coated colour white.

E  
El parasol brazo lateral es robusto. Nuevo soporte vertical y les varillas fabricadí en aluminio ycon acabado especial en imitacion madera color ceniza blanqueda. Componentes en aluminio y acero pintados en polvo color blanco.

D  
Starker Pendelschirm. Neuer Alumast und Streben mit spezial-Eschenholzeffekt. Alu und Stahl Bestandteile pulverbeschichtet, Farbe weiß.

NL  
Robuust vrijhangende parasol: Nieuwe aluminium mast en baleinen met uniek essenhouten uitstraling.

## 21. Palladio Braccio

I  
Ombrellone a braccio laterale robusto. Nuovo sostegno in alluminio con finitura legno, stecche in legno Iroko, componenti in alluminio e acciaio verniciato a polveri colore antracite. Accessori in nylon.

F  
Parasol a bras lateral robust. Nouveau mat en aluminium avec finition bois Iroko. Baleine en bois Iroko. Composants en aluminium laqué gris.

UK  
Strong cantilever parasol. New aluminium support provided with Iroko wood finishing, Iroko wood ribs and aluminium components epoxy coated colour anthracite grey.

E  
El parasol brazo lateral es robusto. Con nuevo soporte en aluminio con acabados imitación madera, varillas de madera de Iroko y componentes en aluminio y acero pintados en polvo color antracita. Accesorios en nylon.

D  
Starker Pendelschirm. Neuer Alumast mit spezial-Irokoholzeffekt. Streben aus Irokoholz. Alu- und Stahlbestandteile aus Aluminium pulverbeschichtet Farbe Anthrazitgrau.

NL  
Robuust Vrijhangende parasol. Mast en aluminium met Iroko uitstraling. Baleinen van Iroko hout. Overige metalen delen grijs geepoxideerd staal.

		MEASURES		CHARACTERISTICS							
	COD			KG	M <sup>2</sup>						
3,0x3,0 NEW	C3030 GIB			75	0,35	-	92x92	ALU TOBACCO	8	INOX	18x30
3,5x3,5	C3535 GIB			70	0,36	-	92x92	ALU TOBACCO	8	INOX	18x30
3,0x4,0	C3040 GIB			70	0,36	-	92x92	ALU TOBACCO	8	INOX	18x30
3,0x3,0 NEW	C3030 MIB			75	0,35	-	92x92	ALU ASH / WHITE	8	ALU ASH	18x30
3,5x3,5	C3535 MIB			80	0,36	-	92x92	ALU ASH / WHITE	8	ALU ASH	18x30
3,0x4,0	C3040 MIB			80	0,36	-	92x92	ALU ASH / WHITE	8	ALU ASH	18x30
3,5	C3500 PAB			75	0,35	-	92x92	ALU IROKO / DARK	8	IROKO WOOD	18x34
3,0x3,0	C3030 PAB			75	0,35	-	92x92	ALU IROKO / DARK	8	IROKO WOOD	18x34
3,5x3,5	C3535 PAB			80	0,36	-	92x92	ALU IROKO / DARK	8	IROKO WOOD	18x34
3,0x4,0	C3040 PAB			80	0,36	-	92x92	ALU IROKO / DARK	8	IROKO WOOD	18x34

FINISHING								COLOUR RANGE							OPTIONAL			BASES			
								ACRYL 350 GR										N°2 BC5151 N°6 BC5050	N°4 BC5151 N°12 BC5050	N°2 BV5050	FISSAGGIO TERRA INGROUND FIX
								A1	A1	A2	A3	A6	A7	S1							
•	•	•	•	•	•	•	•								-	•	•				
•	•	•	•	•	•	•	•								-	•	•				
•	•	•	•	•	•	•	•								-	•	•				
•	•	•	•	•	•	•	•								-	•	•				
•	•	•	•	•	•	•	•								-	•	•				
•	•	•	•	•	•	•	•	-							•	•	•				
•	•	•	•	•	•	•	•								•	•	•				
•	•	•	•	•	•	•	•								•	•	•				
•	•	•	•	•	•	•	•								•	•	•				

## 27. Torino Braccio

**I**  
Ombrellone braccio laterale. Nuovo sostegno in alluminio finitura legno iroko. Stecche in legno Iroko. Componenti in alluminio e acciaio verniciato a polveri colore antracite. Accessori in nylon.

**F**  
Parasol bras lateral. Nouveau mat en aluminium avec finition bois Iroko. Baleine en bois Iroko. Composants en aluminium laqué gris.

**UK**  
Cantilever parasol. New aluminium support provided with Iroko wood finishing, Iroko wood ribs and aluminium components epoxy coated colour anthracite grey.

**E**  
Parasol brazo lateral. Con Nuevo soporte en aluminio con acabados imitación madera, varillas de madera de Iroko y componentes en aluminio y acero pintados en polvo color antracita. Accesorios en nylon.

**D**  
Pendelschirm. Neuer Alumast mit spezial-Irokoholzeffekt. Streben aus Irokoholz. Alu- und Stahlbestandteile aus Aluminium pulverbeschichtet Farbe Anthrazitgrau.

**NL**  
Vrijhangende parasol. Mast en aluminium met Iroko uitstraling. Baleinen van Iroko hout. Overige metalen delen grijs geëpoxeerd staal.

↑	COD	MEASURES		CHARACTERISTICS						
		KG	M <sup>2</sup>	MP	MP	MP	MP	MP	MP	
3,5	C3500 T0B	50	0,20	75x75	ALU IROKO / DARK	8	IROKO WOOD	18x34		
3,0x3,0	C3030 T0B	50	0,20	75x75	ALU IROKO / DARK	8	IROKO WOOD	18x34		
2,0x3,0	C2030 T0B	48	0,20	75x75	ALU IROKO / DARK	8	IROKO WOOD	18x34		
	C3020 T0B									
3,0x4,0	C3040 T0B	55	0,21	75x75	ALU IROKO / DARK	8	IROKO WOOD	18x34		

## 25. Rimini Braccio

**I**  
Ombrellone a braccio laterale robusto. Telaio: alluminio e componenti in acciaio; verniciato a polveri colore bianco. Accessori in nylon.

**F**  
Parasol bras deporté robuste. Armature en aluminium vernis, composants en acier couleur blanc. Accessoires en nylon.

**UK**  
Strong cantilever parasol. Frame: powder coated aluminium and steel components white. Nylon accessories.

**E**  
Parasol con brazo lateral. Estructura: aluminio y componentes de acero, recubierto con polvo color blanco. Accesorios de nylon.

**D**  
Starker Pendelschirm. Gestell: Pulverbeschichtetes Aluminium und Bestandteile aus Stahl Farbe weiss. Zubehoer aus Nylon.

**NL**  
Robuuste vrijhangende parasol. Mast en baleinen: wit geëpoxeerd aluminium en staal.

↑	COD	MEASURES		CHARACTERISTICS						
		KG	M <sup>2</sup>	MP	MP	MP	MP	MP	MP	
3,0x3,0	C3030 RIB	50	0,20	75x75	ALU WHITE	8	ALU WHITE	18x30		
3,0x4,0	C3040 RIB	52	0,21	75x75	ALU WHITE	8	ALU WHITE	18x30		

FINISHING								COLOUR RANGE								OPTIONAL		BASES				
						INOX			ACRYL 350 GR										N°2 BC5151 N°6 BC5050	N°4 BC5151 N°12 BC5050	N°2 BV5050	FISSAGGIO TERRA INGROUND FIX
									A1	A1	A2	A3	A6	A7	S1	P2						
•	•	•	•	•	•	•	•	-	-							-	•	•				
•	•	•	•	•	•	•	•	•									•	•				
•	•	•	•	•	•	•	•	•		-	-	-	-	-	-	-	•	•				
•	•	•	•	•	•	-	•	•									•	•				

FINISHING								COLOUR RANGE								OPTIONAL		BASES				
						INOX			ACRYL 350 GR										N°2 BC5151 N°6 BC5050	N°4 BC5151 N°12 BC5050	N°2 BV5050	FISSAGGIO TERRA INGROUND FIX
									A1	A1	A2	A3	A6	A7	S1	P2						
•	•	•	•	•	•	•	•	•									•	•				
•	•	•	•	•	•	•	•	•									•	•				

## 45. Wood Poker / Double

<p><b>I</b> Struttura robusta composta da 4 ombrelloni (Poker) oppure da 2 ombrelloni (Double) a braccio laterale. Nuovo sostegno verticale in alluminio con speciale finitura effetto Iroko e stecche in legno Iroko. Componenti in acciaio; verniciato a polveri colore antracite. Accessori in nylon.</p> <p><b>F</b> Structure robuste avec 4 parasols (Poker) ou 2 parasols (Double). Nouveau mat vertical en aluminium avec effet bois Iroko et baleines en bois Iroko. Composants en acier couleur gris anthracite. Accessoires en nylon.</p>	<p><b>UK</b> Strong structure made of 4 cantilever parasols (Poker) or 2 cantilever parasols (Double). New vertical aluminium post with special Iroko wood finishing and ribs made of Iroko wood. Steel components powder coated anthracite grey. Nylon accessories.</p> <p><b>E</b> Estructura robusta que se compone de 4 parasoles (Poker) – 2 parasoles (Double) Nuevo soporte vertical en aluminio y con acabado especial en imitacion madera Iroko y varillas en madera Iroko. Accesorios aluminio color gris antracita.</p>	<p><b>D</b> Starke Struktur mit 4 Pendelschirme (Poker) oder 2 Pendelschirme (Double). Alumast mit IrokoHolzeffekt und Streben aus Irokoholz. Bestandteile aus Stahl Farbe Anthrazitgrau. Zubehoer aus Nylon.</p> <p><b>NL</b> Zware mast met 4 (Poker) – 2 (Double) vrijhangende parasols. Nieuwe aluminium mast met uniek Iroko uitstraling. Iroko houtten baleinen. Overige metalen delen: Grijs geëpoxeerd staal.</p>
--	--	---

## 41. Milano Poker / Double

<p><b>I</b> Struttura robusta composta da 4 ombrelloni (Poker) oppure da 2 ombrelloni (Double) a braccio laterale. Nuovo sostegno verticale e stecche in alluminio con speciale finitura effetto frassino sbiancato. Componenti in alluminio e acciaio verniciato a polveri colore bianco. Accessori in nylon.</p> <p><b>F</b> Structure robuste avec 4 parasols (Poker) ou 2 parasols (Double). Avec nouveau mat vertical et baleines en aluminium avec effet bois de frêne. Composants en aluminium et en acier laqué blanc. Accessoires en nylon.</p>	<p><b>UK</b> Strong structure made of 4 cantilever parasols (Poker) or 2 cantilever parasols (Double). New vertical aluminium post and ribs with special ash wood finishing. Aluminium and steel components white epoxy lacquered. Nylon accessories.</p> <p><b>E</b> Estructura robusta que se compone de 4 parasoles (Poker) – 2 parasoles (Double) Nuevo soporte vertical y les varillas fabricadi en aluminio y con acabado especial en imitacion madera color ceniza blanqueda. Componentes en aluminio y acero pintados en polvo color blanco. Accesorios de nylon.</p>	<p><b>D</b> Starke Struktur mit 4 Pendelschirme (Poker) oder 2 Pendelschirme (Double). Neuer Alumast und -Streben mit spezial-Eschenholzeffekt. Alu und Stahl Bestandteile weiss pulverbeschichtet. Zubehoer aus Nylon.</p> <p><b>NL</b> Zware mast met 4 (Poker) – 2 (Double) vrijhangende parasols. Nieuwe aluminium mast en baleinen met uniek essenhouten uitstraling. Aluminium en metalen delen zijn wit geëpoxeerd.</p>
--	---	--

COD	MEASURES		CHARACTERISTICS					
	KG	M <sup>3</sup>	Dimensions	Material	Finish	Accessories		
6,0x6,0 C6060 WPO	185	1,10	120x120	ALU IROKO / DARK	IROKO WOOD	18x34		
7,0x7,0 C7070 WPO	200	1,10	120x120	ALU IROKO / DARK	IROKO WOOD	18x34		
3,0x6,0 C3060 WDO	115	0,90	120x120	ALU IROKO / DARK	IROKO WOOD	18x34		
3,5x7,0 C3570 WDO	130	0,90	120x120	ALU IROKO / DARK	IROKO WOOD	18x34		
6,0x6,0 C6060 MPO	185	1,10	120x120	ALU ASH / WHITE	ALU ASH	18x30		
7,0x7,0 C7070 MPO	200	1,10	120x120	ALU ASH / WHITE	ALU ASH	18x30		
3,0x6,0 C3060 MDO	115	0,90	120x120	ALU ASH / WHITE	ALU ASH	18x30		
3,5x7,0 C3570 MDO	130	0,90	120x120	ALU ASH / WHITE	ALU ASH	18x30		

FINISHING						COLOUR RANGE							OPTIONAL				BASES					
					INOX	ACRYL 350 GR								GOLD			N°2 BC5151 N°6 BC5050	N°4 BC5151 N°12 BC5050	N°2 BV5050	N°4 BV5050	FISSAGGIO TERRA INGROUND FIX	
						A1	A1	A2	A3	A6	A7	S1										
•	•	•	•	•	•	•								•	•	•	•	/		/		
•	•	•	•	•	•	•								•	•	•	•	/		/		
•	•	•	•	•	•	•								•	•	•	•	/		/		
•	•	•	•	•	•	•								•	•	•	•	/		/		
•	•	•	•	•	•	•								•	-	•	•	/		/		
•	•	•	•	•	•	•								•	-	•	•	/		/		
•	•	•	•	•	•	•								•	-	•	•	/		/		

### 43. Alu Poker / Double

I

Struttura robusta composta da 4 ombrelloni (Poker) oppure da 2 ombrelloni (Double). Telaio in alluminio e componenti in acciaio; verniciato a polveri colore antracite. Accessori in nylon.

F

Structure robuste avec 4 parasols (Poker) ou 2 parasols (Double). Armature en aluminium vernis, composants en acier couleur gris anthracite. Accessoires en nylon.

UK

Strong structure made of 4 cantilever parasols (Poker) or 2 cantilever parasols (Double). Frame in coated aluminium and steel components powder coated anthracite grey. Accessories made of nylon.

E









Estructura robusta que se compone de 4 parasoles (Poker) – 2 parasoles (Double). Herrajes: Aluminio y acero color gris antracita. Accesorios de nylon.

D

Starke Struktur mit 4 Pendelschirmen (Poker) oder 2 Pendelschirmen (Double). Gestell aus pulverbeschichtetem Aluminium und Bestandteile aus Stahl Farbe Anthrazitgrau. Zubehoer aus Nylon.

NL

Zware mast met 4 (Poker) – 2 (Double) vrijhangende parasols: Mast en baleinen: Grijs geëpoxeerd aluminium. Overige metalen delen: Grijs geëpoxeerd staal.

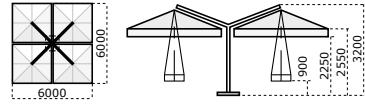
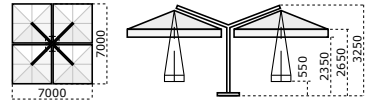
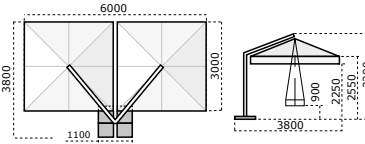
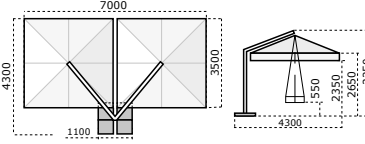
		MEASURES				CHARACTERISTICS					
	 COD										
6,0x6,0	C6060 APO		170	1,00	120x120	ALU DARK	ALU DARK			18x30	
7,0x7,0	C7070 APO		185	1,00	120x120	ALU DARK	ALU DARK			18x30	
3,0x6,0	C3060 ADO		100	0,80	120x120	ALU DARK	ALU DARK			18x30	
3,5x7,0	C3570 ADO		110	0,80	120x120	ALU DARK	ALU DARK			18x30	

### 04. Vela Sail-Parasol

I

Telaio in alluminio anodizzato argento. Viteria in acciaio e componenti in nylon colore bianco.

F

Cadre en aluminium anodisé argent. Visserie en acier et composants en nylon blanc.

UK

Silver anodized aluminum frame. Steel screws and components in white nylon.

E









Estructura de aluminio anodizado color plata, tornillos de acero y componentes de nylon blanco.

D

Silber eloxiertes Aluminium Gestell. Stahlschrauben und Zubehoer aus weißem Nylon.

NL

Het frame is zilverkleurig geëloxeerd met stalen schroeven. Overige bewegende delen zijn van nylon.

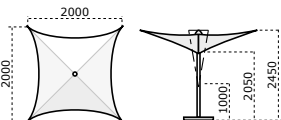
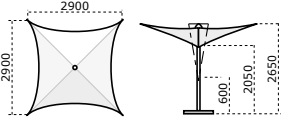
		MEASURES				CHARACTERISTICS					
	 COD										
2,0x2,0	C2020 VSP		11	0,10	50	ALU ANODIZED	4	ALU ANODIZED		18x30	
3,0x3,0	C3030 VSP		14	0,10	50	ALU ANODIZED	4	ALU ANODIZED		18x35	

FINISHING						COLOUR RANGE							OPTIONAL				BASES				
					INOX	ACRYL 350 GR								GOLD			N°2 BC5151 N°6 BC5050	N°4 BC5151 N°12 BC5050	N°2 BV5050	N°4 BV5050	FISSAGGIO TERRA INGROUND FIX
						A1	A1	A2	A3	A6	A7	S1									
•	•	•	•	•	•								•	-	•	•	/		/		
•	•	•	•	•	•								•	-	•	•	/		/		
•	•	•	•	•	•								•	-	•	•	/		/		
•	•	•	•	•	•								•	-	•	•	/		/		

FINISHING		COLOUR RANGE		OPTIONAL		BASES						
		ACRYL 350 GR				BC35	BC55 BC55M	BC80M	BF6565D BF6565Z	BF6666D	BLZ	BTT55+BTC BTT65+BTC
		A6	A7									
•	•			•	•					/	/	
•	•			•	•	/					/	

# Materiali e finiture

## Materials and finishing

### Componenti e profili alluminio

#### Aluminium components and profiles



ALUMINIUM TOBACCO



ALUMINIUM IROKO



ALUMINIUM  
ASH - FRASSINO



DARK

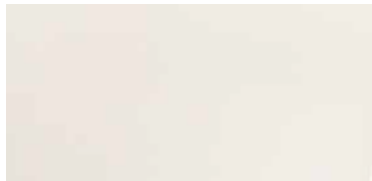

WHITE



INOX COLOUR



ANODIZED

---

### Componenti e stecche legno

#### Wooden components and ribs



IROKO WOOD

## Gamma colori Colours range

### 350 gr/m<sup>2</sup>

ACRYLIC



**A1** ECRU  
NATURAL COL.  
NATUR



**A2** TERRACOTTA  
ZIEGELROT  
TERRACOTTA



**A3** BORDEAUX



**A6** GRIGIO TAUPE  
GREY TAUPE  
GRAU TAUPE  
GRIS TAUPE  
GRIJS TAUPE

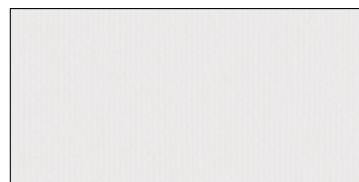

**A7** BIANCO  
WHITE  
BLANC  
WEISS



**S1** NERO  
BLACK  
SCHWARZ  
NOIRE  
NEGRO  
ZWART

### 250 gr/m<sup>2</sup>

POLYESTER



**P2** ECRU  
NATURAL COL.  
NATUR

## Cura dei particolari Finishing care



Galileo

Braccio

# New System

**PATENTED**



I Per tutti gli ombrelloni a braccio vengono introdotte le nuove corone centrali in plastica. Il nuovo sistema è stato studiato da Scolaro per aumentare la resistenza e durata, semplificare la manutenzione e migliorare il design. Inoltre è previsto l'aggancio singolo per ogni stecca che ne rende l'eventuale sostituzione semplice, veloce e alla portata dell'utente finale.

UK For all cantilever parasols new plastic crowns will be employed. The new system studied by Scolaro increases the resistance and long lasting, simplifies the maintenance and improves the design. Furthermore each rib is fixed separately. This makes the replacement easy, quick and within everybody's reach.

D Fuer alle Pendelschirme hat die Firma Scolaro neue Plastikkronen entwickelt. Dieses neue System steigert die Widerstandsfähigkeit und die Dauer, erleichtert die Wartung und verbessert das Design. Alle Streben sind einzeln befestigt. Der Ersatz ist dadurch sehr leicht, schnell und auch seitens des Endverbrauchers ausfuehrbar.

F Pour tous les parasols avec bras déporté la société Scolaro a développé des nouvelles couronnes en plastique. Ce nouveau système augmente la résistance et la durée, simplifie l'entretien et améliore le design. Toutes les baleines sont accrochées individuellement. Le remplacement est très facile, rapide et à la portée de l'utilisateur final.

NL Voor alle zwevende parasols heeft Scolaro een nieuwe kunststof kroon ontwikkeld. Dit nieuwe systeem verhoogt niet alleen de functionaliteit en de duurzaamheid maar vereenvoudigt tevens het gebruik en verfraait de vormgeving. In deze kroon is iedere balein individueel bevestigd. Het vervangen van een balein is daardoor uitermate gemakkelijk, snel en voor iedereen te doen.

# Sole Light



I Nuova lampada per ombrellone wireless con luminosità potenziata del doppio. Colore Nero. Si adatta a tutti gli ombrelloni con palo da 27 a 50 mm. Adatta anche per ombrelloni a braccio. Illuminazione a LED. Ricaricabile come un cellulare: 2 ore di ricarica – circa 6 e di luce. Fissaggio con illuminazione verso il basso e verso l'alto. Carica batterie incluso. Incluso adattatore per ombrelloni a braccio Scolaro.

UK New battery rechargeable light for parasols with increased brightness twice than the previous version. Colour black. Suitable for parasols with pole diameter from 27 to 50mm. LED lights. Rechargeable: 2 hours recharging – 6 hours light. Down- and up light. AC Adapter included. Adaptation accessory for Scolaro's cantilever parasols included.

D Neue batteriebetriebene/wireless Beleuchtung fuer Schirme mit gesteigerter Lichtstaerke. Farbe schwarz. Eignet sich fuer alle Schirme. Ab Mastdurchmesser 27 bis 50mm. Auch fuer Pendelschirme geeignet. LED Beleuchtung. Wiederaufladbar: 2 Stunden Wiederladung – 6 Stunden Beleuchtung. Beleuchtung nach oben oder nach unten moeglich. Aufladegeraet inbegriffen. Anpassungsteil fuer die Befestigung an Scolaro Seitenarmschirme inbegriffen.

F Nouveau éclairage pour parasols avec luminosité potencé. Couleur noir. Fonctionnement par batterie incorporée. Compatible sur mât de 27mm à 50mm. Possible sur parasol avec bras éxcentré. Éclairage LED. Rechargeable en 2 heures pour 6 heures d'autonomie. Éclairage orientable. Chargeur inclus.

E la primera lampara wireless por sombrilla, que se adapta a todos los sombrillas con palo desde 27 a 50 mm. Apta tambien para sombrillas a brazo. Iluminacion LED. Recargable como un mobil. 2 horas de carga-cerca de 6 horas de luz. Se puede fijar con la iluminacion en direccion del suelo o del cielo. El carga bateria está incluido.

NL Snoerloze PARSOLVERLICHTING Geen probleem meer met losse snoeren. Deze snoerloze parasolverlichting past op alle ronde parasolbuizen met een diameter tussen de 27 mm. en 50 mm. en kan zowel naar boven als naar beneden gericht worden. Ook geschikt voor het gebruik op de zwevende parasols uit het Scolaro sortiment. Eenvoudig te bevestigen dankzij een verend klemmechanisme. Het bijpassende oplaadapparaat (110V / 220V) wordt meegeleverd.

# USO E MANUTENZIONE

## Acciaio Inox

### Attenzione:

1. NON USARE i seguenti prodotti su parti in acciaio inox:  
Candeggina o detersivi contenenti candeggina (possono corrodere l'acciaio inox).  
Acido cloridrico o prodotti contenenti cloruro (possono corrodere l'acciaio inox).
2. Sale, calcare o acido (bevande o alimenti) possono scolorare le parti in acciaio inox non prontamente pulite.
3. Prodotti o parti in acciaio inox usati in riva al mare o nell'arredo a bordo piscina richiedono più frequenti pulizie per rimuovere i depositi di cloruro e prevenire la corrosione e l'attacco chimico della superficie esterna.
4. Macchie o ruggine che si presentano sulla superficie di acciaio inox devono essere prontamente pulite.
5. Macchie lasciate a lungo possono divenire permanenti.
6. La ruggine può attaccare chimicamente o scavare l'acciaio inox.

### Rimozione di macchie o ruggine:

- Applicare un detersivo non abrasivo specifico per l'acciaio inox.
- Sciacquare abbondantemente con acqua pulita.
- Alla fine asciugare bene per prevenire striature, strofinare nel senso delle fibre.

## Metalli verniciati: Ferro – Alluminio

Per la pulizia delle superfici in metallo verniciato utilizzare acqua fredda e detersivi liquidi non abrasivi e non aggressivi. Applicare con panno morbido. È consigliabile, in caso di superfici molto sporche e/o invecchiate, di trattare, dopo la fase di pulizia, con olio di vaselina. Applicare con panno morbido per rivitalizzare le superfici. Nell'eventualità di macchie dovute a depositi calcarei, passare un panno con soluzione di aceto bianco diluito in acqua fredda.

Prima della stagione invernale eseguire una fase di pulizia e quindi trattare superfici, parti mobili e viti con olio di vaselina, utilizzando un panno morbido.

Piccoli graffi o danneggiamenti delle superfici verniciate, dovuti a trasporto, usi impropri o movimentazione, possono essere ritoccati e protetti dalla corrosione con apposita vernice.

## Legni: Iroko

Tradizionale legno impiegato nell'arredo da esterni e nel settore nautico.

È un legno duro ad alto contenuto di olio adatto all'uso esterno. Estremamente longevo, è praticamente inalterabile all'esposizione reiterata agli agenti atmosferici. Se non riceve alcun trattamento protettivo, la superficie prenderà una patina grigio argento, naturale protezione della parte interna del legno.

La tendenza naturale del legno di ingrigire o perdere la luminosità della vernice può essere impedita nella fase iniziale di vita del prodotto. È sufficiente trattare nuovamente le parti in legno con impregnante adatto, facile da trovare nei negozi specializzati.

Si applica con un panno, sulle superfici esposte, una soluzione di acqua e olio incolore.

L'olio deve essere molto diluito. Quando la superficie è asciutta, lucidare con panno.

Macchie superficiali possono essere rimosse intervenendo in modo tempestivo, prima che il legno possa assorbirle in profondità.

Carteggiare la superficie interessata e successivamente lucidare con panno.

La corrispondenza ad alti standard qualitativi e funzionali dei materiali impiegati costituisce la garanzia principale della robustezza e resistenza nel tempo dei prodotti Scolaro. Un comportamento rispettoso di norme di manutenzione ed uso, come specificato di seguito, assicura una durata ancora maggiore.

Le informazioni contenute in questo catalogo o in altri stampati pubblicitari della ditta Scolaro, quali caratteristiche tecniche dei prodotti o dei componenti, dimensioni, schemi di montaggio, colori, ecc., hanno valore meramente indicativo, in ragione delle specifiche tecniche e della evoluzione tecnologica dei prodotti aziendali. Al fine di migliorare la qualità del prodotto, la ditta si riserva il diritto di modificare lo stesso senza alcun preavviso e anche dopo l'accettazione dell'ordine. L'azienda si riserva di apportare modifiche parziali o totali ai prodotti senza preavviso declinando ogni responsabilità su eventuali dati inesatti. Eventuali lievi variazioni di tonalità dei colori e delle finiture rientrano nelle normali caratteristiche dei materiali impiegati. Tutte le differenze sopraindicate non sono tali da modificare significativamente i prodotti stessi e non costituiscono motivo di reso o sostituzione della merce o di contestazione.

## Tessuti sintetici: Acrilico – Poliestere

Il tessuto impiegato è trattato antimuffa ed impermeabilizzato per respingere al massimo l'acqua e le macchie mantenendone la traspirabilità. Si raccomanda di seguire le istruzioni seguenti di manutenzione per rendere ottimale la durata del tessuto:

– Togliere periodicamente depositi di polvere, macchie e altro tipo di sporco per evitare che anche dopo la pulizia rimangano tracce visibili.

– È importantissimo assicurarsi che la copertura sia perfettamente asciutta prima di chiudere l'ombrellone.

Durante i mesi di non utilizzo l'ombrellone deve essere riposto in un ambiente asciutto.

Evitare il contatto prolungato con sostanze grasse e/o coloranti che potrebbero venire assorbite dal materiale di rivestimento e dare luogo a macchie permanenti, oltre che deteriorare la struttura del filato. Non usare solventi o detersivi a base di solventi (evitare l'acetone). Utilizzare acqua e detersivi liquidi non abrasivi con PH neutro e incolori. Eventualmente lasciare agire il detersivo alcuni minuti. Sciacquare abbondantemente con acqua a temperatura non superiore a 30°C.

## Componenti

Le parti in acciaio, la viteria e gli accessori sono trattati antiruggine. Per garantire e assicurare una maggiore durata del prodotto è consigliabile comunque porre l'ombrellone e la base al riparo durante i mesi invernali o durante i periodi di non utilizzo. Durante ogni stagione verificare periodicamente lo stato e la funzionalità dei componenti soprattutto dopo un periodo lungo dove l'ombrellone non sia stato utilizzato.

## Avvertenze

Leggere attentamente e conservare le istruzioni di montaggio e il manuale d'uso.

La base va zavorrata con il peso indicato. L'insufficienza di peso sulla base compromette seriamente la stabilità dell'ombrellone.

In caso di vento chiudere sempre l'ombrellone e rimuoverlo dalla struttura. Non lasciare mai l'ombrellone incustodito aperto. Improvvisi colpi di vento possono danneggiare o rovesciare l'ombrellone.

Ricordare sempre che l'ombrellone non è una struttura fissa.

La ditta Scolaro non potrà essere ritenuta responsabile per danni ai prodotti forniti, cose o persone derivanti da un utilizzo scorretto e dal mancato rispetto delle istruzioni e direttive su riportate.

## Uso Prodotti

Prima di iniziare la manovra di apertura accertarsi che il telo dell'ombrellone non sia impigliato nelle stecche interne.

Per aprire o chiudere gli ombrelloni girare le manovelle nel senso indicato dalle frecce e dalle diciture "apre" o "chiude": errate manovre possono rompere la corda o il meccanismo.

Non forzare mai le funi o le manovelle: se c'è un impedimento accertarsi della sua origine e rimuovere l'eventuale causa.

Componenti in legno: applicare almeno una volta ogni anno un impregnante.

Corde e parti meccaniche: trattare con olio di vaselina una volta ogni anno prima della stagione invernale. Chiudere gli ombrelloni in presenza di avverse condizioni meteorologiche quali vento e pioggia di forte intensità.

Gli ombrelloni Scolaro sono associabili a specifici basamenti per il fissaggio a terra.

Se si sceglie di posizionarli solo tramite zavorra si certifica la loro idoneità ad un uso normale in condizioni di vento moderato.

Nella tabella dedicata vengono riportate le indicazioni sui pesi minimi delle zavorre.

La fase di installazione dell'ombrellone e la sua gestione è responsabilità esclusiva del Cliente.

## Garanzia

I prodotti Scolaro sono garantiti per 2 anni da:

-difetti strutturali non dovuto ad suo improprio o mancata manutenzione

-ruggine invasiva non derivante da graffi o abrasioni da uso e non asportabile con normale pulizia e manutenzione.

La garanzia é limitata a 1 anno per i meccanismi di apertura a manovella.

Sono esclusi dalla garanzia danni al tessuto come tagli ed abrasioni non rilevati al momento della consegna o derivanti da uso improprio.

Per avvalersi della garanzia, è necessario presentare l'articolo difettoso o foto del prodotto.

Sono richiesti anche copia della fattura o scontrino. Scolaro declina ogni responsabilità per danni causati a cose o a persone derivanti da uso non corretto del prodotto.

La garanzia prevede la fornitura di pezzi di ricambio o la sostituzione del prodotto dove necessario.

La garanzia non contempla l'intervento in loco o altri costi sostenuti per il mancato uso del prodotto.

# USE AND MAINTENANCE

## Stainless steel

### Attention:

1. DO NOT USE THE FOLLOWING PRODUCTS on any parts made of stainless steel:  
Chlorine bleach or detergents containing bleach (they can corrode stainless steel).  
Hydrochloric acid or products containing chlorides (they can corrode stainless steel).
2. Salt, limestone or acids (drinks and food) may discolour parts made of stainless steel if not cleaned promptly.
3. Products or parts made of stainless steel used near the seaside or for the interior decoration of swimming pools require more frequent cleaning in order to remove chlorides deposited on them and to prevent corrosion and chemical deterioration of the external surfaces.
4. Stains or rust noted on stainless steel surfaces must be cleaned promptly.
5. Stains left in place for long periods may become permanent.
6. Rust may cause chemical reactions or corrode stainless steel.

### To remove stains or rust:

- Apply a specific non-abrasive detergent or polish for stainless steel.
- Rinse thoroughly with clean water.
- Lastly, dry thoroughly in order to prevent streaks from occurring, rubbing in the sense of the fibres.

The connection between the high qualitative and functional standards of the materials used, constitutes the main guarantee of the sturdiness and the resistance of the company's products over time. Respecting the rules of maintenance and use, specified as follows, will ensure the success of these objects, which were devised with Sclaro quality, to last a long time.

## Varnished metals: Iron and Aluminium

To clean surfaces in varnished metals, use cold water and non-abrasive or aggressive liquid detergents.

Apply with a soft cloth. In the case of very dirty and/or aged surfaces, after cleaning, it is advisable to treat them with liquid paraffin. Apply with a soft cloth to revitalize the surfaces. In the event of stains caused by lime deposits on varnishes of coarse structure (eg. antique iron and indian brown) clean them with a cloth and a solution of white wine vinegar diluted in cold water. Before winter, carry out the cleaning phase and then treat the surfaces, moving parts and screws with liquid paraffin, using a soft cloth. Small scratches or damage to the varnished surfaces due to transportation, improper use or handling can be retouched and protected from corrosion with special varnishes.

## Wood: Iroko

Traditional wood employed for outdoor furniture and the marine industry. Iroko is a hardwood with a high oil content, suitable for external use. Extremely long-lasting. It is practically unalterable to repeated exposure to atmospheric factors. If not treated, the surface takes a silver-grey coating which is the natural protection from inside the wood, considered an essential part of Iroko's charm.

The natural tendency of wood to turn gray or lose the brightness of the paint can be prevented in the early stages of the product life. The parasol can be restored by a new treatment with proper products easy to find in specialized shops.

It's necessary to apply a solution of water and colourless oil, to exposed surfaces with a cloth. The oil must be highly diluted. When the surface is dry, polish with a cloth. Superficial stains can be removed by intervening in time, before the wood can fully absorb them. Gently sand the surface in question and then polish with a rough cloth.

The information contained in this brochures or other Sclaro's advertisements prints, such as product specifications or components, dimensions, assembling instruction, colours, etc., are purely indicative, because of the technical specifications and the technological evolution of the company's products. In order to improve the quality of the product, the company reserves the right to change the same without prior notice and even after acceptance of the order. The company reserves the right to make partial or complete changes to the products without prior notice and declines any responsibility for inaccurate data. Any colour differences and changes of finishing have to be considered normal characteristics of the materials used. These differences do not significantly change the products and aren't reason for return or replacement of the goods or dispute.

## Synthetic fabrics: Acryl and Polyester

The fabric is waterproof and anti mould treated to reject water, spots and grant transpiration. Please follow our maintenance instruction to grant the long lasting of the fabric:

- Remove often dust deposits, spots and any type of dirt in order to avoid trails after cleaning.
- It's very important to close the parasol only when it is perfectly dry. During the winter and when the parasol is not employed, it has to be stored in dry environment.

Avoid prolonged contact with oily substances and/or dyes that could be absorbed by the covering material in PVC and cause permanent stains, in addition to damaging the structure of the thread. Do not use solvents or solvent-based detergents (avoid acetone).

Use water and non-abrasive, colourless liquid detergents with a neutral PH. Let the detergent act for a few minutes. Rinse well with water no warmer than 30°C.

## Components

The steel components, screws and accessories are anti rust treated. Anyway for a long lasting of the parasol, during the winter and when the it is not employed, the parasol has to be stored in dry environment.

During every season it is necessary to check the functionality of all components, especially after a long period of non-employ. The company Scolaro is at your disposal for technical assistance.

## Directions

- Before use, directions and assembling instructions, which are inside the package, have to be kept and read carefully .
- The base has to be ballasted. An insufficient weight will seriously compromise the stability of the parasol.
- Always remove crank when not in use and keep out of reach of children.
- To avoid damage or personal injury, parasol must be closed and removed from the support when unattended and/or in windy conditions.  
Remember always that the parasol is not a fixed construction. The company Scolaro cannot be held responsible for damages to goods supplied, or injury resulting from improper use and failure to follow instruction and guidelines given on.

## Product Employ

Before starting to open the umbrella, make sure that the fabric has not got caught in the internal ribs. To open or close the umbrella, turn the handle in the direction indicated by the arrows and the works "Open" or "Close". Incorrect operation could tear the string or damage the mechanism. Never force the ropes or handles. If they get stuck, check why this has happened and eliminate the possible cause.

Wooden parts: apply a wax-based wood-stainer at least once a year before the winter season.

Close the umbrella when the weather conditions are unsuitable, i.e. strong wind or heavy rain.

Scolaro umbrellas can be combined with special bases developed for the ground fixing.

If it is decided to position a Scolaro umbrella using ballast only, their suitability for use in conditions of moderate wind is certified. In the specific table the minimum ballast weights are indicated. The Customer is the sole party responsible for installing and managing the umbrella.

## Warranty

The products Scolaro are warrantied for 2 years against:  
-structural faults not resulting from improper use or lack maintenance.

-invasive corrosion not produced by scratches or abrasions from use not removable through normal cleaning and maintenance  
The mechanism with handle for the opening are warrantied for 1 year.

Any damage to the fabric such as cuts and abrasions not found put upon delivery or resulting from improper use shall be excluded. To take advantage of the warranty the faulty item must be shown or pictures must be forwarded, together with the invoice or receipt. Scolaro declines any liability for any damage to properties or individuals deriving from an improper use of the product. The warranty includes the supply of spare parts or the replacement of the product if necessary. The warranty does not include the repair on-site or the refund of costs incurred for non-use of the product.



IBIZA



MOROCCO



PADOVA



ZAGREB - CROATIA



MOROCCO



MOROCCO



ROMA



PADOVA



MODENA



REPUBLIC CZECH



MILANO



PADOVA



SIRMIONE - LAGO DI GARDA



DOHA - QATAR



MALTA



LIMA - PERU



SIRMIONE - LAGO DI GARDA



CALABRIA



KITZBÜHEL - AUSTRIA



ASCOLI PICENO



LIGNANO - VE



RIMINI



SINGAPORE



VENEZIA - LIDO



MOROCCO



POLAND



SINGAPORE



ALASSIO - SAVONA



78 SINGAPORE



VENEZIA - LIDO



VERONA



VENEZIA - LIDO



GERMANY



MALTA



DUBAI



FINLAND



ALASSIO - SAVONA



PORTO - GENOVA



VENEZIA - LIDO



POLAND

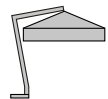

	BASES				
	N° 2 BC5151 N° 6 BC5050	N° 4 BC5151 N° 12 BC5050	N° 2 BV5050	N° 4 BV5050	FISSAGGIO A TERRA INGROUND FIX
Ø 3,5				/	BTB
Ø 4,0	/		/		BTB
3,0 x 3,0				/	BTB
3,5 x 3,5				/	BTB
4,0 x 4,0	/		/		BTB
2,0 x 3,0				/	BTB
3,0 x 4,0				/	BTB
<hr/>					
3,0 x 3,0 Galileo	/			/	BTB
3,5 x 3,5 Galileo	/			/	BTB
4,0 x 4,0 Galileo	/		/		BTB
3,0 x 4,0 Galileo	/			/	BTB
<hr/>					
5,0 x 5,0 Capri	/		/		
5,0 x 6,0 Capri	/		/		
6,0 x 6,0 Capri	/		/		
3,0 x 6,0 Double	/		/		
3,5 x 7,0 Double	/		/		
<hr/>					
6,0 x 6,0 Poker	/		/		
7,0 x 7,0 Poker	/		/		

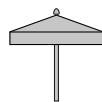

	BASES						
	BC35	BC55 BC55M	BC80M	BF6565D BF6565Z	BF6666D	BLZ	BTT55 + BTC BTT65 + BTC
Ø 2,5			/	/	/	/	
Ø 3,0				/	/	/	
Ø 3,5	/			/	/	/	
Ø 4,0	/						
Ø 5,0	/	/		/			
2,0 x 2,0			/	/	/	/	
3,0 x 3,0	/						
3,5 x 3,5	/						
4,0 x 4,0	/	/		/			
2,0 x 3,0					/	/	
3,0 x 4,0	/						

I

Queste tabelle sono indicative e prevedono che il pavimento o il terreno di appoggio sia perfettamente piano e regolare. Gli ombrelloni e i rispettivi componenti delle basi devono essere assemblati correttamente rispettando le istruzioni di montaggio. La stabilità degli ombrelloni può variare nel caso di condizioni atmosferiche particolari. L'utilizzatore finale è responsabile del corretto uso dell'ombrellone. Nessuna rivalsa può essere fatta sul produttore.

UK

This schedule considers statics calculation and foresees that the floor where the parasol has to be positioned is perfectly flat and regular. The parasols and components have to be assembled correctly and respecting the assembly instruction. The schedule has to be considered indicative because many variables that depend from the area of employ and position of the parasols are not foreseeable. No rights can be derived from this. The use of a parasol is always on your own responsibility.

D

Diese Aufstellung beinhaltet statistische Kalkulationen und sieht vor, dass der Schirm auf einem ebenen und regelmaessigen Boden positioniert wird. Der Schirm und die Bestandteile des Staenders muessen gemaess Anbauanleitungen montiert werden. Die Stabilitaet der Schirme kann auf Grund besonderer klimatischen Konditionen aendern. Der Endbenutzer ist fuer die ordnungsgemaesse Verwendung des Schirmes verantwortlich.

F

Ces tableaux sont à titre indicatif et ils prévoient que la surface sur laquelle est implanté le parasol soit parfaitement plane et lisse. Les parasols et les éléments respectifs des bases doivent être assemblés en respectant scrupuleusement les instructions de montage. La stabilité des parasols peut varier dans le cas de conditions atmosphériques particulières et dépend du lieu et de l'utilisation propre à chaque utilisateur (le parasol doit être fermé en cas de vent fort et/ou de mauvaises conditions météorologiques).

E

Estos cuadros son indicativos y requieren que el suelo o el apoyo de tierra sea perfectamente plano y liso. El parasol y los respectivos componentes de la base deben ser montados correctamente respetando las instrucciones. La estabilidad de los parasoles puede variar según las condiciones atmosféricas.

NL

This schedule considers statics calculation and foresees that the floor where the parasol has to be positioned is perfectly flat and regular. The parasols and components have to be assembled correctly and respecting the assembly instruction. The schedule has to be considered indicative because many variables that depend from the area of employ and position of the parasols are not foreseeable.





.Dimensione (metri)  
 .Dimensions (meters)  
 .Masse (Meter)  
 .Dimensions (metrès)  
 .Dimensiones ( en metros)  
 .Afmeting in (meters)



.Stecche  
 .Ribs  
 .Streben  
 .Baleines  
 .Varillas  
 .Baleinen



.Piastrre cemento  
 .Cement slabs  
 .Kiesbetonplatten  
 .Dalles ciment  
 .Planchas de cemento  
 .Betontegel



.Viteria in inox e ottone nichelato  
 .Screws in Stainless steel and nickel plated brass  
 .Edelstahlschrauben und vernickeltes Messing  
 .Visserie inox et laiton nickelé  
 .Tornillos en acero inoxidable y bronce niquelado  
 .Schroeven van rvs en vernikkeld messing



.Codice  
 .Code  
 .Artikelcode  
 .Code  
 .Código  
 .Artikelcode



.Set canaline  
 .Raingutter set  
 .Regerinnen  
 .Set gouttières  
 .Canalizador Lluvias  
 .Set regengoten



.Fodero  
 .Cover bag  
 .Schutzhuelle  
 .Housse  
 .Ferro  
 .Afdekhoes



.Tipo finitura della struttura/sostegno/componenti  
 .Finishing for frame/structure/components  
 .Ausfuehrung des Gestells/der Struktur/der Bestandteile  
 .Finition armature/structure/composants  
 .Tipo de acabadò de la estructura/Soportes/componente

👁 Pag. 68



.Lunghezza  
 .Length  
 .Laenge  
 .Longueur  
 .Longitud  
 .Lengte



.Con base/supporto  
 .With base/support  
 .Mit Staender/Huelse  
 .Avec base/support  
 .Con base/ soporte  
 .Inclusief standaard



.Doppia carrucola  
 .Double pulley  
 .Doppelter Seilzug  
 .Double poulie  
 .Doble polea  
 .Dubbelle katrollen

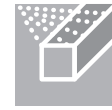

.Colore dei componenti/stecche  
 .Component/Ribs colour  
 .Farbe der Bestandteile und Streben  
 .Couleur des composants et baleines  
 .Color de los componentes ò piezas/Varillas ò listones



.Peso  
 .Weight  
 .Gewicht  
 .Poids  
 .Peso  
 .Gewicht

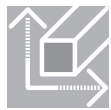

.Sezione stecche  
 .Rib section  
 .Strebenprofil  
 .Section baleines  
 .Sección varillas  
 .Profil baleinen



.Sistema telescopico  
 .Telescopic system  
 .Teleskopsystem  
 .Système telescopique  
 .Sistema telescópico  
 .Telescoop systeem



.Stecca con sistema "easy change"  
 .Ribs with "easy change" system  
 .Streben mit "easy change" System  
 .Baleines avec "easy change" système  
 .Varillas con sistema de " cambio fácil"  
 .Baleinen met het "easy change" systeem



.Volume (m3)  
 .Volume (m3)  
 .Volumen (m3)  
 .Volume (m3)  
 .Volumen (m3)  
 .Volume (m3)



.Camino antivento  
 .Wind cap  
 .Windfang  
 .Souffle  
 .Chimenea antiviento  
 .Windvang



.Sistema retrattile  
 .Retractile system  
 .Einziehbares System  
 .Système retractile  
 .Sistema retráctil  
 .Inklapbaar systeem



.Ø Palo (mm)  
 .Ø Pole (mm)  
 .Ø Mast (mm)  
 .Ø Mat (mm)  
 .Diametro mm (asta)  
 .Ø Mast (mm)



.Volant  
 .Valance  
 .Volant  
 .Volant  
 .Faldón  
 .Volant



.Base girevole a 360°C  
 .Revolving base 360°C  
 .360°C drehbarer Staender  
 .Base tournant 360°C  
 .Base giratoria 360°  
 .360° draaibaar



.Massima Stabilità Ottenibile  
 .Maximum Obtainable Stability  
 .Maximal Erhaeltliche Stabilitaet  
 .Maximum De Stabilité Realisable  
 .Maxima Estabilidad Posible  
 .Maximaal Bereikbare Stabiliteit



.Sezione sostegno (mm)  
 .Support section (mm)  
 .Mastprofil (mm)  
 .Section support (mm)  
 .Sección soporte (mm)  
 .Mast (mm)



.Blocco antivento  
 .Wind stop  
 .Windstop  
 .Block antivent  
 .Freno para el viento  
 .Windstop



.Inclinazione fino a 20°  
 .Inclination up to 20°  
 .Neigung bis zu 20°  
 .Inclination jusqu'à 20°  
 .Inclinación hasta 20°



.Peso consigliato in condizioni normali  
 .Recommended weight in normal condition  
 .Empfohlenes gewicht unter normalen bedingungen  
 .Poids recommande dans des conditions normales  
 .Peso recomendado en condiciones normales  
 .Aanbevolen gewicht onder normale omstandigheden



.Ottonatura  
 .Brassfinishing  
 .Vermessungen  
 .Laiton doré  
 .Terminaciones doradas  
 .Koper beslag



.Con meccanismo manovella  
 .With winding mechanism  
 .Mit Kurbelmechanismus  
 .Avec mécanisme manivelle  
 .Con manivela  
 .Met opwindmechanisme



.Inclinazione fino a 60°  
 .Inclination up to 60°  
 .Neigung bis zu 60°  
 .Inclination jusqu'à 60°  
 .Inclinación hasta 60°



.Peso minimo richiesto  
 .Minimum ballast required  
 .Erforderliches mindestgewicht  
 .Poids minimum requis  
 .Peso minimo requerido  
 .Minimaal vereist gewicht